

TARARUA DISTRICT COUNCIL

PROPOSED PLAN CHANGE 1

UNDER PART 1 SCHEDULE 1 RESOURCE MANAGEMENT ACT 1991

DECISION OF THE HEARING COMMISSIONERS

**Commissioners:
Chris Mitchell (chair), Shirley Hull, and Robert Schofield**

Date of Hearing: 9 October 2017

Date of decision: 13 December 2017

Contents

1.	Introduction	3
2.	Formal Decision	3
3.	Plan Change 1	4
4.	Statutory and Planning Framework	6
5.	Submissions	9
6.	Hearing	10
7.	Assessment	13
8.	Further Evaluation under Section 32AA	24
9.	Conclusion	25
10.	Appendix 1	
11.	Appendix 2	

1. Introduction

1. The Tararua District Plan ('the Plan') was made operative in September 2012. In October 2016 the Council proposed the first change to the Plan with the notification of Plan Change 1 (PC1). PC1 has been generally described as a 'tidy up' plan change, covering a diverse range of matters which have arisen since 2012. A summary of those matters is contained in Section 3 of PC1:
2. Four generic categories of matters requiring change to the District Plan are described in PC1, as follows:
 - **National Policy Statements and Standards** where changes to the District Plan's provisions are required to acknowledge or give effect to a higher order national planning instrument
 - **Regional Policy Statement and Plan** provisions which necessitate changes to the District Plan as a consequence of the MWRC's One Plan becoming operative.
 - **District plan content changes** required as a consequence of problems or concerns identified in the course of administering the provisions of the Operative District plan or Councillor acknowledged concerns raised by the citizens of the District.
 - District Plan changes of a minor updating or technical nature which do not involve substantive content changes.
3. Submissions on PC1 closed on 25 November 2016 and nine submissions were received. Further submissions closed on 17 January 2017 and two were received.
4. On 31 May 2017 Council resolved to appoint a hearing panel of Chris Mitchell (Chair), Robert Schofield and Councillor Shirley Hull, and delegated to this panel the necessary functions and powers to hear and determine PC1 and the submissions on it. PC1 includes proposed alterations to designations - which would require a recommendation to the relevant requiring authority if there had been any submission requests on them - but there were not, so it was unnecessary to consider these alterations.

2. Formal Decision

5. PC1 is accepted subject to the amendments made by this decision shown in Appendices 1 and 2. The reasons for this decision are those set out in paragraphs 60-121 below. The requests made in submissions and further submissions on PC1 are accepted, accepted in part or rejected to the extent shown by those amendments in Appendix 1 (a summary of decisions by submission) and in Appendix 2 (the relevant provisions as amended by this decision). Further submissions are accepted or rejected according to the decisions on the submissions to which they relate.

6. Where, in relation to any request made in a submission, a specific reason for the decision is not given, that reason will be either in the submission itself (in the case of acceptance) or in the relevant section 42A report (in the case of acceptance in part or rejection). Though we have tried to be flexible in considering the intent of a submission, it has not always been possible to identify a specific and relevant request on which a decision is required.

3. Plan Change 1

7. This section of the decision describes Plan Change 1 in more detail. For this purpose, the description follows the four generic categories listed in section 1 above.

National Direction

8. PC1 addresses three matters arising in this category:
 - Giving effect to Policy F of the National Policy Statement for Renewable Electricity Generation ('NPSREG') 2011
 - Consistency with the National Environmental Standard for Telecommunications Facilities (NESTF) 2008
 - Consistency with changes in the laws relating to the management of hazardous substances

9. The NPSREG Policy F contains the following direction:

POLICY F

As part of giving effect to Policies E1 to E4, regional policy statements and regional and district plans shall include objectives, policies, and methods (including rules within plans) to provide for the development, operation, maintenance and upgrading of small and community-scale distributed renewable electricity generation from any renewable energy source to the extent applicable to the region or district.

10. Council is required to give 'effect to' any NPS in its Plan. PC1 proposes to give effect to Policy F by making 'domestic scale electricity generation from renewable energy resources' a permitted activity subject to standards. This activity is to be defined. Community scale generation remains a discretionary activity under Rule 5.3.7.2.
11. PC1 also proposes a minor rewording to permitted activity standard 5.3.7.2(a).
12. National Environmental Standards exist independently of the district plan, and where relevant, in place of any district plan requirements. NES rules apply nationally. In that sense, a district plan does not need to 'give effect to' NES, but should avoid provisions which may conflict or be inconsistent with them.
13. PC1 proposes three minor changes to reflect NESTF and the Telecommunications Act 2001.

14. PC1 proposes the removal of a number of Plan provisions, including rules, relating to hazardous substances. The enactment of regulations under the Hazardous Substances and New Organisms Act 1996, the Health and Safety at Work Act 2015, and the NES on Soil Contaminants 2011 have made the relevant Plan provisions redundant. In addition, section 31(1)(b)(ii) RMA, which gave the Council functional responsibility for *the prevention or mitigation of any adverse effects of the storage, use, disposal, or transportation of hazardous substances* was repealed earlier this year.

Regional Policy Statement and Plan

15. Since the Plan became operative in 2012, the Regional Council's One Plan has become operative. The One Plan includes the Regional Policy Statement ('RPS') which the Plan must 'give effect to', and Regional Plan provisions with which the Plan must 'not be inconsistent'.
16. PC1 addresses three matters in this category:
- Biological diversity/indigenous vegetation and habitat provisions
 - Minimum lot sizes for wastewater disposal
 - Natural (Flood) Hazards

Biological Diversity

17. The Plan must give effect to RPS Policy 6-1. This Policy allocates responsibility for maintaining indigenous biodiversity within the context of land use activities to the Regional Council rather than the District Council, but as land use activities do not include subdivision, this Policy does not apply to subdivision.
18. Giving effect to this Policy, PC1 proposes the removal of a number of rules and of Schedule 3.2 in Appendix 3, and a range of consequential amendments.

Minimum lot sizes for wastewater disposal

19. Under Regional Rule 14-14 domestic wastewater discharge is permitted on a new allotment provided that its area is at least 5,000m². If an allotment is smaller than this, the discharge is a discretionary activity.
20. PC1 proposes an amendment to Rule 5.1.2.2(c)(i) to align the subdivision rules with the Regional rule, with an advisory note following this rule.

Natural (Flood) Hazards

21. RPS Policies 9-1(c) and 9-2(b) require the Council to identify areas 'known to be inundated by a 0.5%AEP flood event and control development within such areas.
22. PC1 proposes a new introduction in section 5.1.7.1 which outlines these RPS policies and describes the Council's approach to its obligations under them.

District Plan content changes

23. PC1 proposes substantive changes to the content of the District Plan in relation to the following topics:
- Council advisory/warning signs: new permitted activity category in Rule 5.4.3.2(b)
 - Off-site signs in Rural Management Area: new performance standard in Rule 5.4.3.2(d)
 - Earthworks in Rural Management Area: replacing 200m³ limit with 1,000m³ in Rules 5.1.5.2(b)(i) and (ii)
 - Outdoor living courts: amendment to Rule 5.4.3.2(c) in relation to decks
 - Screening standards and derelict vehicles, buildings and sites: provisions applying to all management areas which make any activity on a derelict site a discretionary activity.

District Plan updating and minor corrections

24. PC1 proposes changes to a number of existing provisions:
- Parking and manoeuvring, vehicles access and crossing standards: Appendices 6-12
 - Verandahs: linking retail frontages in Schedule 16.1 with map references
 - Resource consent application format: amendments to Rules 7.3.2 and 7.3.3
 - Updating of references: a range of updated references to higher level (national and regional) policies, descriptive text, and planning maps
 - Designations uplifted or updated: changes to Schedule 4.

4. Statutory and Planning Framework

Statutory Framework

25. The statutory framework within which district plan changes are to be prepared and considered is described succinctly in Section 1.2 of PC1 as notified. We endorse that description and it is not necessary to repeat it.
26. For the purposes of this decision, we are particularly concerned with the following aspects of the statutory framework:
- Council's functional responsibilities under section 31
 - The evaluation of PC1 under section 32
 - The need for any further evaluation under section 32AA

- The requirement to give effect to higher order policies under section 75
 - The requirement to be not inconsistent with regional plan provisions under section 75
 - Requirements in relation to rules under sections 75 and 76
 - Requirements in relation to decisions on submissions under Schedule 1 Part 1.
27. In relation to section 31, two matters are important:
- In 2017 (after PC1 was notified) section 31(1)(b)(ii) was repealed. This clause related to the control by territorial authorities of *the prevention or mitigation of any adverse effects of the storage, use, disposal, or transportation of hazardous substances*. The repeal of this clause follows the completion of regulation of these matters under other statutes and regulations.
 - Under section 31(1)(a) the Council has, in broadly expressed terms, responsibility for the establishment, implementation, and review of objectives, policies, and methods to achieve integrated management of the effects of the use, development, or protection of land and associated natural and physical resources of the district. Under section 31(2) the methods used to carry out the functions under section 31(1) may include the control of subdivision.
28. Under section 31(b)(iii), one of the functions of the District Council under the RMA is *the maintenance of indigenous biological diversity*. However, the Regional Council also has specific responsibility under section 30(1)(ga) for *the establishment, implementation, and review of objectives, policies, and methods for maintaining indigenous biological diversity*. To address this 'overlap' in responsibilities, RPS Policy 6-1 has identified that the Regional Council is to give effect to this Policy in relation to land use controls. However, because Council has sole responsibility for the control of subdivision (and Policy 6-1 affects only land use) the protection of indigenous biological diversity may be achieved by the control of subdivision under the District Plan.
29. In relation to section 32AA, a further evaluation is required in relation to any changes made to PC1 following its notification. The further evaluation must address the matters in section 32(1)-(4).
30. The Plan must give effect to relevant national and regional policy statements. In practice, higher order policy statements are often not directive as to exactly what provision must be made within a district plan. For example, as noted above, NPSREG requires district plans 'to provide for' small and community-scale distributed renewable electricity generation: this can be given effect to in a range of ways, in different parts of a district. By contrast, NES Standards are national rules which generally prevail over district rules in case of conflict.

31. The Plan should not have provisions which are inconsistent with relevant regional rules. Thus, for example, a regional rule which requires a discretionary activity consent for onsite discharge of domestic wastewater on an allotment of less than 5,000m² will effectively require that any district rule relating to subdivision assign at least the same consent category for the creation of such an allotment.
32. Section 76 provides that rules may be made for the purpose of carrying out the Council's functions (under section 31) and achieving the objectives and policies of the Plan.
33. Schedule 1 Clause 10 requires the Council to make a decision 'on the provisions and matters raised in submissions'. For the purposes of decision making, submissions may be grouped according to the provisions or the matters they relate to. There is no requirement to address each submission individually.

Planning and Policy Framework

34. The relevant aspects of the planning/policy framework are those which have been referred to above, namely:
 - National Policy Statement on Renewable Electricity Generation ('NPSREG')
 - National Environmental Standard for Telecommunications Facilities ('NESTF')
 - The Manawatu-Wanganui Regional Council's Regional Policy Statement ('One Plan RPS')
 - The Manawatu-Wanganui Regional Council's Regional Plan ('One Plan Regional Plan').
35. The District Plan was made operative in 2012, having been notified in 2009. Its preparation and completion thus overlapped with NPSREG which was notified in 2008 and came into force in 2011. The NESTF first came into effect in 2008, and was subsequently reviewed and revised in 2016. The Horizons One Plan did not become operative until December 2014.

36. The requirement for the District Plan to 'give effect' to relevant national and regional policy statements. As the Supreme Court has noted, 'give effect to' simply means 'implement'¹. The Court went on to note:

[80] We have said that the “give effect to” requirement is a strong directive, particularly when viewed against the background that it replaced the previous “not inconsistent with” requirement. There is a caveat, however. The implementation of such a directive will be affected by what it relates to, that is, what must be given effect to. A requirement to give effect to a policy which is framed in a specific and unqualified way may, in a practical sense, be more prescriptive than a requirement to give effect to a policy which is worded at a higher level of abstraction.

37. The 'not inconsistent' requirement is clearly a constraint on district rules covering the same matters covered by rules which apply either nationally (through an NES) or regionally (through a regional plan).
38. The first two categories of matters addressed by PC1 relate to these requirements to 'give effect to' and not be 'inconsistent with' policies and rules which were largely brought into force either after the Plan was notified or after it became operative.

5. Submissions

39. As recorded above, there were nine submissions on PC1, and then two further submissions. Further submissions are limited to expressing (and explaining) support of or opposition to submissions - they cannot raise any new matters. In this decision further submissions are considered along with the submissions to which they relate.
40. The submissions are well summarised in the section 42A report to the hearing panel. We accept that summary. In this part of the decision we simply list the submissions and further submissions made on PC1 together with a brief outline of the topic(s) covered.
- **J W Blathwayt:** supports PC1, particularly measures to deal with 'eyesores'
 - **D E Bray:** supports provisions which address the problem of 'eyesores', and including power for Council to issue removal notices
 - **The NZ Transport Agency (NZTA):** supports permitted status for Council advisory/warning signs subject to consultation with NZTA where a sign fronts a state highway; requests amendments to Appendices 8 and 10.
 - **A Poulton:** supports PC1, particularly measures relating to 'eyesores'; though a concern is expressed the owners responsible for the eyesores may not have the means to remedy them, thus imposing a financial burden on the community.

¹ *Environmental Defence Society Inc v New Zealand King Salmon Company Ltd* [2014] 1 NZLR 593, [2014] NZRMA 195

- **Royal Forest and Bird Protection Society of New Zealand Inc ('Forest and Bird')**: submission relates to significant indigenous vegetation and significant habitats, with concern expressed over uncertainty as to how the Council intends to implement relevant policies and what 'non-regulatory' methods are to be used. Requests that these methods be identified, and that Schedule 3.2 be retained.
- **Powerco Limited**: Generally supports PC1 in relation to proposals on renewable electricity generation, hazardous substances, indigenous vegetation and natural (flood) hazards. Requests amendments to standard 5.3.7.2(a) and two relevant definitions. Powerco also made a **further submission** in opposition to specific requests in the Federated Farmers and Horizons submissions.
- **Federated Farmers of New Zealand**: generally supportive of PC1 but requests amendments to provisions on renewable electricity generation, minimum lot sizes for wastewater disposal, and eyesore screening.
- **Manawatu-Wanganui Regional Council (Horizons)**: general support for PC1 provisions relating to renewable electricity generation and indigenous vegetation; requests amendments to provisions on hazardous substances and minimum lot sizes for wastewater disposal; does not support provisions on natural (flood) hazards and says these do not give effect to RPS.
- **Z Energy Limited, Mobil Oil NZ Limited, and BP Oil NZ Limited (the "Oil Companies")**: supports deletion of hazardous substances provisions. The Oil Companies also made a **further submission** in opposition to the Horizons submission's request on hazardous substances.

6. Hearing

41. PC1 was heard on 9 October 2017, in the Council Chambers in Dannevirke. The Hearing Panel was assisted by Joan Spencer, Committee Secretary.
42. **The Council** was represented by David Forrest, Consultant District Planner, and Nicole McPeak, Senior Planning Officer.
43. **Forest and Bird** was represented by Tom Kay, Lower North Island Regional Manager.
44. **Horizons** was represented by Mhairi Rademaker, Consultant Planner, and Barry Gilliland, Senior Policy Analyst.
45. Written material was received from the following submitters who did not attend the hearing:
 - **Federated Farmers**: letter of 20 September, having seen the section 42A report, is now 'comfortable' with PC1.
 - **NZTA**: email of 21 September, having seen the section 42A report, is now 'comfortable' with recommendations in it.

- **Powerco:** letter of 3 October (Burton Consultants), no longer wishes to attend hearing.
 - **Oil Companies:** letter of 3 October (Burton Consultants), statement on hazardous substances (reiterating support for PC1), and natural (flood) hazards (commenting on the section 42A report recommendation to accept Horizon's submission in part) pointing to an unintended consequence of recommended Standard 5.1.7.2(b) and requesting amendment.
46. The Council had made a report under section 42A and sent it to the Commissioners and to all submitters prior to the hearing. The two submitters who attended the hearing helpfully provided and addressed written material in support of their submissions.
47. The hearing followed a conventional approach of beginning with the Council introducing the proposed plan change, then proceeding to hear from each submitter, and then allowing the Council a right of reply. However, within this broad format, the limited number of participants and the nature of the issues led to a more 'round table' hearing, where each party was invited to identify points of agreement or disagreement with other parties, so that these aspects (and any opportunities for consensus) could be identified. This approach complemented the valuable work undertaken by Council prior to the hearing and, we think, has largely reduced the aspects of significant disagreement.
48. On the major issues canvassed during the hearing, we record our understanding of the parties' respective positions as follows.

Hazardous substances

49. The Horizons submission requests that the Council retain some land use controls over the storage, use of transport of hazardous substances, particularly in relation to sensitive areas and activities, land prone to natural hazards, and reverse sensitivity. As noted above, Powerco and the Oil Companies opposed that submission (and also, with Federated Farmers, supported the PC1 approach).
50. At the hearing Horizons acknowledged that the repeal of relevant Council functions in sections 30 and 31 in April 2017 has largely resolved its concerns. In regard to the location of major hazardous facilities near sensitive activities (such as residential) Horizons acknowledged the Council position that hazardous facilities (defined in the Plan to include those which store or handle hazardous substances) are generally discretionary activities, and the issue of potential reverse sensitivity can be address through the resource consent process. Horizons did not advance a more specific request.

Natural (Flood) Hazards

51. Horizons remains of the view that Council has not fully given effect to RPS Policies 9-1 and 9-2. Policy 9-1 requires flood prone areas to be identified, while Policy 9-2 generally requires the avoidance of development within flood prone areas.

52. Council does not accept that it has failed to give effect to these policies. However, the recommendations made in the section 42A report go some way towards addressing the Horizons concerns that the Plan does not adequately manage development within flood prone areas. Horizons accepted these recommendations subject to a minor wording amendment which Council, in turn, accepted as appropriate.

Minimum lot sizes for wastewater discharges

53. Horizons indicated that it accepts the recommendations in the section 42A report to retain reference in Rule 5.1.2.2(c)(i) to a drainage easement as an acceptable method of compliance (as requested by the Federated Farmers submission), and to include the advisory note requested in its submission.

Indigenous vegetation

54. Forest and Bird's primary concern is, evidently, that PC1 would result in areas of significant indigenous vegetation or habitat in the District being left unprotected as a result of the withdrawal of regulatory controls from the Plan. Forest and Bird notes that whilst relevant Plan policies are to be retained, the relevant rules and Schedule 3.2 are not. It requests that Schedule 3.2 be retained and that the Council identify other non-regulatory methods to ensure integration between Regional and District Plans. At the Hearing, Mr Kay proposed five amendments to address these concerns. We summarise these as follows (noting that the full amendments are contained at pages 3-5 of his statement:

- add indigenous biodiversity as a matter to be considered in subdivision consents
- add 'values' to environmental features in subdivision assessment criteria
- retain Schedule 3.2
- add Schedule 3.2 as an implementation method for Policy 2.6.4.2
- add new implementation method for Policy 2.6.4.2 - cooperation between Council and Horizons

55. In response, Horizons does not strongly disagree with any of Forest and Bird's fundamental concerns, but wishes to avoid duplication, and the attendant potential for uncertainty. It is for that reason that Horizons considers that Schedule 3.2 should be removed. In Mr Gilliland's view the areas covered in that Schedule are all likely to be within the Horizons database, but conversely the database will include habitats and areas not identified in the Schedule. He noted that other territorial authorities in the Region have or were intending to remove schedules and rules on indigenous biodiversity. If the Schedules is retained, he asserted that it is important to make it clear that the areas within them are a small proportion of areas covered by the Regional Plan.

56. Mr Gilliland said that there is good communication between the Horizons and the Council, and that Horizons is notified by the Council of subdivision applications, which allows it to review proposed earthworks which may have an effect on indigenous biodiversity. However, he also emphasised that Policy 6-1 does not affect Plan rules on subdivision, and thus there is still a role for the Council to consider indigenous biodiversity values through the subdivision process.
57. For Council, Mr Forrest noted that Schedule 3.2 is incomplete and he would not support its retention, as it would send the wrong message about the extent of protection of indigenous biodiversity. He also noted that, in preparing the One Plan, it was generally agreed by territorial authorities that Horizons field staff were much better placed to actually monitor activity in rural areas.
58. In terms of the amendments requested by Mr Kay, Mr Forrest was happy to accept amendments 1 and 5 subject to wording changes (which he undertook to send). He thought that the additional wording proposed by amendment 2 is redundant. And he thought that amendments 3 and 4, which retain and reference Schedule 3.2, should not be accepted because the regional data base and rules are more comprehensive.
59. The hearing was concluded, and Mr Forrest was asked to submit his proposed rewording of Forest and Bird's recommendations 1 and 5. These were received by Commissioners on 13 October 2017.

7. Assessment

60. This part of the decision is an assessment of the decisions requested in the various submissions, together with a record of our reasons for accepting or rejecting these requests. These individual decisions on requests and the changes made to PC1 are summarised in Appendices 1 and 2 to this decision.
61. Our approach to decision making must be an evidence based one, as we will now explain. PC1 as a whole is supported by evidence initially in the form of an evaluation under section 32 and then, with a focus on the changes requested in submissions, in the section 42A report. Where a submission requests that PC1 be changed, it is incumbent of the person making the request to give sufficient reasons for this. In the absence of such reasons, it is difficult to accept a request.
62. We also note that proposals which have not received any requests for change in submissions do not require any decision (or recommendation in the case of designations). In other words, any aspect of PC1 which is not subject to submission remains unchanged save for any minor alteration or correction that needs to be made under Schedule 1 Clause 16(2).
63. For the purposes of this assessment, we have approached the submissions in two categories:
- those topics where the only requests made in submissions were recommended for acceptance in substance by the Council in the section 42A report

- those topics where some of the requests made in submissions have been opposed in whole or part by the Council, in other submissions or in further submissions.
64. In regard to the latter category, we note that some submitters have subsequently accepted the position of the Council and its rationale for its position.

Topics where all requests are agreed to in substance by Council

65. There are eight topics in this category:
- Giving effect to NPSREG
 - Hazardous substances
 - Noting NESTF
 - Minimum lot sizes for on-site wastewater disposal
 - Advisory/warning signs
 - Earthworks
 - Parking manoeuvring, vehicle access and crossing standards
 - Updating and minor corrections of Plan provisions

Giving effect to NPSREG

66. There were three submissions requests on the changes related to giving effect to NPSREG. The submission from Horizons supports the provisions as notified. The submission from Powerco supports the provisions but requests 'precautionary statements' regarding connections to the network. Federated Farmers supports the proposals but requests clarifying amendments to Rule 5.3.7.2(a) and the definition to ensure that renewable electricity generation for primary production activities is included.
67. In relation to the Powerco submission, the Council recommends an advisory note following Rule 5.3.7.2(a). The Council's recommended wording is a little broader than sought by Powerco, but we think that the reference to relevant legislation is appropriate. For the reason given in 5.2.2 of the section 42A report, Council does not recommend any amendment to the definition of 'domestic scale electricity generation'. We agree that the concept of domestic scale generation does not depend on network connection - whether or not such a connection is made or used does not affect the nature of the activity. Network connection may or may not occur dependent on decisions from both the electricity producer and the network owner. These decisions not only have a commercial context, but will be subject to other regulatory standards relating to network connections which are outside both the Plan and the RMA.

68. In relation to the Federated Farmers submission, we accept that the use of the word 'domestic' may raise some question as to whether it is limited only to households. The word 'small' used in NPSREG Policy F may have been a better choice. However, the definition, in our view, does allay the concern:

Domestic scale electricity generation from renewable energy sources means generating electricity on a site to meet the needs of the users of that site and includes the export from the site of any surplus electricity to a local electricity distribution network.

69. In our opinion, it is clear from this definition that the scale of the electricity generation must be at a domestic level – i.e., at a private small-scale level, as opposed to large-scale, industrial/commercial level. Further, the definition is similar to the definition in Policy F NPSREG in that it does not specify the exact use to which the electricity generated on a site is to be made, other than to meet the needs of the users of the site: it may therefore be for residential, primary production, industrial or other activity taking place on the site. It is the relatively minor scale of the generation facility that is the key consideration.
70. We have also considered the definition of 'site', and consider that the second 'limb' will include all contiguous primary production activities whether or not they occur on land within a single certificate of title. In our view, therefore, the PC1 proposals adequately cover the Federated Farmers concerns about ambit. We note that Federated Farmers is 'comfortable' with the section 42A report's recommendation.
71. On this basis, the submission from Horizons is accepted, and the submissions from Powerco and Federated Farmers are accepted in part.

Hazardous substances

72. There were four submissions on the hazardous substances amendments proposed by PC1. Powerco, Federated Farmers and the Oil Companies all supported the proposals as notified. Horizons supported the proposal but raised concerns as to their extent and timing.
73. We note, as Horizons did in its presentation at the hearing, that the relevant clauses in sections 30 and 31 have now been repealed and thus the control of land use for the purposes of preventing or mitigating adverse effects from 'storage, use, disposal, or transportation of hazardous substances' *per se* is no longer an explicit function of either Council.
74. We acknowledge that the removal of this specific function does not totally remove the obligation of the Councils to address the potential effects as part of their broader functions under the RMA. In particular, as Horizons noted, it might still be important to control the potential effects - including reverse sensitivity effects - of 'major hazardous substances facilities'. In the section 42A report (at p.8) Council says that there are no such facilities currently in the District, but if one was to be proposed it would be a discretionary activity. We note that the Plan defines 'hazardous facility' (and that definition is unaffected by PC1) but it does not appear to be specifically classified as a discretionary activity. A number of industries which *might* be within this definition are covered by Plan Appendix 1. However, a specific resolution of any 'gap' in this regard is well beyond our remit: we have neither a specific

request, nor sufficient information on which to make a change to the Plan. It will be an issue for future consideration by Council.

75. Our understanding is that Horizons broadly accepts this conclusion.
76. On this basis, the submissions from Powerco, Federated Farmers and the Oil Companies are accepted and the submission from Horizons is accepted in part.
77. Following the repeal of relevant paragraphs in sections 30(1)(c)(v) and 31(b)(ii), it is appropriate to make some minor amendments to the respective last paragraphs of both proposed 5.1.8.1 Introduction and proposed Reasons section 2.9.4.5. These last paragraphs are accordingly amended as follows:
 - 5.1.8.1: When these HSNO and HSWA responsibilities are combined with the responsibility of the Regional Council to manage hazardous substances and the discharge of contaminants into the environment, the Council considers there is no need or justification for to provide any further regulations (rules) or other provisions in the District Plan in order to exercise its RMA S31(1)(b) functions.
 - 2.9.4.5: When the responsibilities of these statutory bodies are combined with the responsibilities of the Regional Council to manage hazardous substances and the discharge of contaminants into the environment, the Council considers there is no need or justification for to provide any further regulations (rules) or other provisions in the District Plan in order to exercise its RMA S31(1)(b) functions.

Noting NESTF

78. Federated Farmers' submission supports the inclusion of the proposed reference to NESTF.
79. This submission is accepted. The recommended amendments to refer to the 2016 NESTF (now in force) is accepted under Clause 16(2) as an alteration of minor effect.

Minimum lot size for on-site wastewater disposal

80. The submission from Federated Farmers requested the retention of existing reference in Rule 5.1.2.2(c)(i) to a drainage easement being a means of compliance where there is insufficient area of land within the relevant certificate of title. Horizons does not oppose this request. Council recommends acceptance.
81. The submission from Horizons requests minor amendments to advisory notes for Rules 5.2.3.2 and 5.1.2.2. Council recommends its acceptance.
82. The submissions from Federated Farmers and Horizons are accepted.

Advisory/warning signs

83. The NZTA submission requested that the new permitted activity classification (Rule 5.4.3.2(b)(viii)) be subject to a requirement to consult with NZTA. This request was opposed by Powerco's further submission.
84. We agree that making permitted activity status contingent on prior consultation is potentially problematic. However, we also agree that the intent of the request is valid: NZTA is responsible for the safe and efficient function of state highways, and official signage might affect these matters. On that basis we also agree that the recommendation in the section 42A report to substitute 'consultation' with 'approval' is both legally practical and achieves the intent of considering any NZTA perspective. Creating an effective veto may appear somewhat rigid, but the rule applies only to Council signs, and we are confident that, as between two relevant agencies, any issues of clarity and safety can be resolved.
85. This submission is accepted.

Earthworks

86. Federated Farmers supports the proposal to increase the permitted volume of earthworks in the Rural Management Area from 200m³ to 1,000m³.
87. This submission is accordingly accepted.

Parking manoeuvring, vehicle access and crossing standards

88. NZTA has made a number of requests in relation to Appendix 8 and Appendix 10. The requested changes are to bring the Plan into consistency with relevant NZTA standards. The section 42A report recommends acceptance of these requests for reasons given at section 5.10.2 of the report. We agree.
89. This submission is accepted.

Updating and minor corrections of Plan provisions

90. Federated Farmers and Horizons both support the minor changes listed in Section 6.4 of PC1.
91. These submissions are accepted.

Topics where request not agreed to by Council

92. There are three topics in this category:
- Indigenous Biodiversity
 - Natural (Flood) Hazards
 - Screening standards and derelict vehicles, buildings and sites

Indigenous biodiversity

93. This topic occupied most of the hearing, and we have recorded the respective positions of Forest and Bird, Horizons and Council at pages 10-12 above. We also note here that submissions from Powerco and Federated Farmers supported the PC1 proposals.
94. The starting point is the obligation on Council to give effect to RPS Policy 6-1:

Policy 6-1: Responsibilities for maintaining indigenous biological diversity²

In accordance with s62(1)(i) RMA, local authority responsibilities for controlling *land*[^] use activities for the purpose of managing indigenous *biological diversity*[^] in the Region are apportioned as follows:

a. The Regional Council must be responsible for:

- i. developing objectives, policies and methods for the purpose of establishing a Region-wide approach for maintaining indigenous *biological diversity*[^], including enhancement where appropriate
- ii. developing *rules*[^] controlling the use of *land*[^] to protect areas of significant indigenous vegetation and significant habitats of indigenous fauna and to maintain indigenous *biological diversity*[^], including enhancement where appropriate.

b. Territorial Authorities[^] must be responsible for:

retaining schedules of notable trees and amenity trees in their *district plans*[^] or such other measures as they see fit for the purpose of recognising amenity, intrinsic and cultural values associated with indigenous *biological diversity*[^], but not for the purpose of protecting significant indigenous vegetation and significant habitats of indigenous fauna as described in (a)(ii) above.

² The [^] symbol indicates a word defined in the RMA

c. Both the Regional Council and *Territorial Authorities*[^] must be responsible for:

recognising and providing for matters described in s6(c) RMA and having particular regard to matters identified in s7(d) RMA when exercising functions and powers under the RMA, outside the specific responsibilities allocated above, including when making decisions on *resource consent*[^] applications.

95. Our understanding of Policy 6-1 is that, under (b), the District Plan's land use rules should not attempt to manage effects on indigenous biodiversity, including both vegetation and habitat values. However, under (c), subdivision rules and assessments of resource consents will still need to take into account these matters under section 6(c) and 7(d) Resource Management Act. There does not appear to be any dispute on this. And, to a large degree, we also think it answers Forest and Bird's concern that the withdrawal of the Plan provisions proposed by PC1 diminishes the Council's ability to 'recognise and provide for' or 'have particular regard to' these provisions.
96. In fact, the result of giving effect to Policy 6-1 is the reduction or elimination of any ambiguity as to which Council is responsible for the making of objectives, policies and rules to protect indigenous biodiversity and intrinsic values of ecosystems. As with many aspects of environmental management, close cooperation between the Councils will be necessary to achieve the desired results - but that does not require potential duplication within planning documents.
97. Forest and Bird questioned how the remaining Plan policies were to be implemented without the rules. We think that the concern may be misconceived. Policies do not have to be implemented by rules - and, of course, cannot be in this case where the RPS directs that the primary regulatory document is to be the regional plan. However, we will return below to the request for a specific reference in the subdivision rules which, as we noted above, are not subject to Policy 6-1 and therefore have some relevance in relation to this matter.
98. Horizons did not, as we understand it, strongly oppose Forest and Bird's request to retain Schedule Appendix 3.2. However, Council was concerned that the Schedule covers only part (and perhaps a small part) of the areas actually protected by the One Plan. Horizons agreed with this. Forest and Bird did not dispute the point. We therefore conclude that Schedule 3.2 does not serve any purpose within the Plan as amended, and may actually have the potential to mislead Plan users about the extent of protection.
99. Council and Horizons agreed that the requests 1 and 5 defined in the Forest and Bird presentation were appropriate, but Mr Forrest thought that some rewording would be helpful. In relation to request 1, Mr Forrest's proposed rewording was:

**Add a matter for control under Land Subdivision Rules:
Subdivision Standards: Classification of Activities: Section 5.2.4.3
- 'Matters over which the council reserves control in relation to
controlled activities' to read:**

"In respect of the controlled activities listed in 5.2.4.2 above, the matters over which the Council shall exercise control by the imposition of conditions are:

(g) the measures necessary to avoid or mitigate adverse effects on indigenous biodiversity, including those required to protect vegetation and habitat consistent with this Plan's 2.6.4.2 Policies.

100. The recommended addition of the word 'necessary' and a minor rewording of the policy reference are the only changes from that proposed by Forest and Bird, and in our view do not affect the substance of the request.

101. In relation to request 5, Mr Forrest's proposed rewording was:

2.6.4.4 Methods:

102. The Council shall implement policies 2.6.4.2 (a), (b) and (c) by the following methods:

103. District Plan and resource consents - The Council has included in this District Plan, in Appendix 3, a Schedule of Significant Trees, ~~a Schedule of Significant Indigenous Vegetation and Significant Habitats of Indigenous Fauna,~~ and a Schedule of Natural Features and Landscapes, and has adopted rules which aim to control the adverse effects of activities at, or in close proximity to these listed items. The Schedules classify the items as Category A or B according to their significance and the level of protection required. The scheduled significant trees, ~~significant indigenous vegetation and significant habitats of indigenous fauna~~ and natural features and landscapes are identified on the District Plan maps. **[Refer to Part 9 of the Plan].**

104. "In respect of resource consent enquiries and processing, the Council shall work with the Regional Council to recognise and provide for S6(c) of the RMA and achieve consistent implementation of the respective Councils' functions for the maintenance of indigenous biological diversity. In particular, the Council shall consult with the Regional Council when land use or subdivision consent applications are being considered which may, were consent to be granted, have adverse effects on indigenous vegetation or habitats."

The Council has also included a set of provisions for the protection of unscheduled areas of significant indigenous vegetation. These provisions will enable an activity in an unscheduled area to be assessed on a case by case basis in order to establish whether the vegetation concerned is "significant" and, if it is significant, whether or not it should be protected.

Amend the existing and add a new explanatory paragraph to section '2.6.4.3 Explanation', on page 2- 54, as follows:

The MWRC, in its ~~Proposed One Plan~~, has ~~stated that it will take~~ the lead role in managing indigenous biodiversity in the Region. The ~~Proposed One Plan~~ includes rules that control activities in rare and threatened habitats and at risk habitats. It ~~will is therefore be unnecessary for the District Plan to include these rules as well~~. The ~~Proposed One Plan~~ also states that the Regional Council will work with landowners to maintain or protect and enhance these the [rare and threatened and at risk] habitats.”;

It is therefore important that the District Plan not be inconsistent with the objectives and policies of the ~~Proposed One Plan~~ and that the Council give effect to the Regional Council's policy (RPS) in respect of the management of biodiversity once this has been determined by due process. However, given the time necessary for the provisions of the ~~Proposed One Plan~~ to be considered and determined, it will be necessary to retain the current provisions in the District Plan relating to biodiversity, particularly Rule 5.5.4.

Whilst the Regional Council takes primary responsibility for maintaining indigenous biological diversity in the District, by using (inter alia) rules to control the use of land to protect areas of significant indigenous vegetation and habitat, the Council will continue to exercise its responsibilities in relation to any matters not regulated by the Regional Council such as when considering and determining resource (land use and subdivision) consent applications. It will work closely with the Regional Council to ensure that Policy 6- 1 of the Operative One Plan is implemented in a consistent and effective manner as detailed in method (a) of 2.6.4.4 Methods.

Policies 2.6.4.2(d) and (e) aim to assist landowners in the management of indigenous biodiversity on private land and to support the efforts of the Regional Council, landowners, and other agencies (such as the QEII Trust) in the management of indigenous biodiversity.

105. The rewording proposed by Mr Forrest focuses the new text on the processing and assessment of resource consent applications, rather than more generally as proposed by Forest and Bird. We think that the proposed focus adds clarity to the method and defines (as Forest and Bird requested) just how the policy elements are to be implemented.
106. Given our decision above on the retention of Schedule 3.2, we do not accept Forest and Bird's specific requests 3 and 4.
107. Forest and Bird request 2 is to add the words 'and values' after 'environmental features'. In context, we think that this tends to create an inapt, and possibly unintended, distinction between a feature and its values. As Mr Forrest noted, the essence of some features - such as landscape or cultural - is the values that define them. The statutory definition of 'environment' includes the 'social, economic, aesthetic and cultural conditions' which affect or are affected by ecosystems, people and communities, resources and amenity values. So, having regard to this background, we do not favour interpolating the word 'values'.

108. We therefore accept specific requests 1 and 5, as reworded in Appendix 2 on the basis that they improve and clarify PC1. We do not accept request 2, 3 and 4 for the reasons given above.
109. The Forest and Bird submission is accordingly accepted in part, and the submissions from Horizons, Powerco and Federated Farmers are accepted save for the amendments to PC1 resulting from the Forest and Bird submission.

Natural (Flood) Hazards

110. Powerco and Federated Farmers have made submissions supporting the PC1 proposal as notified.
111. Horizons' submission asserts that PC1 does not give effect to RPS Policy 9-1(c). The concern is that the Plan will not identify areas prone to inundation. The relevant part of Policy 9-1(c) reads:

c. Territorial Authorities[^] must be responsible for:

i. developing objectives, policies and methods (including *rules*[^]) for the control of the use of land[^] to avoid or mitigate *natural hazards*[^] in all areas and for all activities except those areas and activities described in (b)(ii) above, and

ii. identifying ***floodways***^{*} (as shown in ***Schedule J***¹) and other areas known to be inundated by a 0.5% annual exceedance probability (AEP) flood event² on planning maps in *district plans*[^], and controlling land[^] use activities in these areas in accordance with Policies 9-2 and 9-3.

112. It is important to note that the Tararua District is a large land area with a relatively population. Accurate flooding data for much of the District is sparse, and Horizons does not suggest otherwise, though it has identified catchments for which it does hold information, and Horizons has funding to develop further information over the next few years. In our view, the requirement to give effect to this Policy needs to be subject to implementation which is practically possible. In other words, where reliable information on flood risk is available it should be used to identify any evident flood hazard.
113. Horizons has made three specific requests which it considers will better give effect to policy 9-1. These requests are an amended definition of 'natural hazard areas'; an amendment to Section 5.1.7.1 Introduction; an advisory note to Section 5.1.7.
114. The recommendation in the Section 42A report at 5.6.2 and 5.6.3 broadly supports these specific requests.

115. However, the recommendation also includes a new Rule 5.1.7.2(b) which creates a specific flood hazard standard for 'land identified by MWRC as a natural hazard (flood) area'. Whilst we agree that this also gives effect to Policy 9-1(c)(ii), it was not specifically requested by any submitter - the Horizons request for 'any alternative relief' must, in our view, be restricted to modifications around specific requests. The recommendation has strong pragmatic appeal, but we think that accepting it would go beyond permissible limits for a decision on the Horizons submission. We also note that the recommended standard would have an 'ambulatory' character where the land subject to it will depend on 'identification' in some form by Horizons, outside the District Plan.
116. This does not mean that there is a 'loophole' in developing land subject to inundation in a 0.5%AEP flood event. Both section 106 and the Building Act continue to apply, and where consent is required, any available flood information will generally be considered.
117. Accordingly, we accept recommendations (a), (b) and (d), but not (c), in section 5.6.3 of the section 42A report. The submissions from Powerco, Federated Farmers, and Horizons are all accepted in part to this extent.

Derelict sites

118. This topic received four submissions. The submissions from JW Blathwayt, DE Bray and A Poulton support the PC1 proposals, although the submission from Mr Bray also requested a provision allowing Council to issue a removal notice in respect of eyesore material. The submission from Federated Farmers broadly supports the amenity purpose behind the proposed provisions but is concerned that ordinary farm structures 'not built or maintained with beauty in mind' may be regarded as derelict: it therefore requests that the provisions apply only to site of less than 2ha.
119. We note that the Federated Farmers letter of 20 September 2017 states that, having reviewed the section 42A report, it is now 'comfortable with where this Plan Change has landed'.
120. Dealing with the purpose of the request, we accept that much of the Rural environment is a working one. The same could be said of industrial and commercial sites. Functionality and aesthetics may not go hand in hand. It is also true, and important in this context, that amenity expectations will not be the same across all areas covered by the proposed provisions. So an activity may 'detract to an observable, significant degree from amenity, character or appearance of land' in one area, but the same activity may not have the same effect in another area.
121. We also note the point that standards and definitions for permitted activities need to be objective. In this instance, the definition of 'derelict site' contains largely objective elements. Paragraphs (a) and (c) are matters of factual assessment rather than opinion. Paragraph (b) certainly may involve a judgment about whether the condition of land or structures is unsightly or objectionable, but such a judgment can be made on an objective basis in its context.

122. Overall, we are satisfied that the provisions as proposed are appropriate to assist with the management of these, no doubt relatively few, instances of eyesores when they arise. We do not accept that any specific provision or limitation needs to be made for the Rural Management Area.
123. Mr Bray's specific request for power to issue a removal notice is covered by the enforcement provisions of the RMA under which Council can issue an abatement notice, or seek an enforcement order, in relation to Plan non-compliance or situations where there is a significant offensive or objectionable element. For this reason, we would not accept a duplication of this power in the Plan itself - it already exists and is defined by statute.
124. The submissions from Mr Blathwayt and Mr Poulton are accepted. The submissions from Mr Bray and Federated Farmers are accepted in part.

8. Further Evaluation under Section 32AA

125. As we noted at para.29 above, we are required to undertake a further evaluation of PC1 under section 32AA. That further evaluation is required only for changes to the proposal since the original section 32 evaluation, and 'must be undertaken in accordance with s.32(1) - (4)', and must also be 'at a level of detail that corresponds with the scale and significance of the changes'. (Section 32AA(1)(a)-(c)).
126. We have made a number of generally minor changes to the provisions proposed by PC1. Many of these changes are simply to achieve better clarity and/or effectiveness, or references to other relevant provisions. In the scheme of s.32, we do not regard these changes as significant - in our view they make PC1 more workable without altering anything of fundamental importance. In the language of section 32(1)(b) we have made the relevant provisions more efficient and effective without changing any of the factors under section 32(2).
127. PC1 did not involve any change to Plan Objectives or Policies. The changes to policy sections are generally to expand on or update reasons and methods of implementation. The evaluation required under section 32, and thus, by extension, the further evaluation under section 32AA, applies then only to 'provisions' - introductory and/or explanatory text is not included.
128. The proposed new rule on derelict sites is unchanged, and in our view the section 32 evaluation was sufficient. Nevertheless, we would add that we think that the new rule is entirely consistent with Objective 2.6.2.1 and Policy 2.6.2.2 and, these being District wide provisions, we did not think it appropriate to differentiate the application of the rule between different parts of the District. We think that the new rule is sufficiently flexible to be applied everywhere the issue arises.
129. For the purposes of section 32(2), we do not think that the changes would have any significant or quantifiable impact on economic growth or employment opportunities. The more permissive provisions on small scale electricity generation are required to give effect to NPSREG, but may also have a positive economic impact on households and businesses.

130. We think that the appropriate level of information was available for all decisions.
131. Section 32(4) does not apply as there has been no proposal to introduce a 'greater prohibition or restriction on an activity to which a national environmental standard applies.'

9. Conclusion

132. Plan Change 1 has been approved with few significant amendments. The majority of the amendments appear to be acceptable to the people who made submissions on the relevant provisions. The process was greatly simplified by the constructive approach of submitters and the work of Council's planners, and we thank all participants for their work on these issues.
133. It is axiomatic that planning is never completed. Responses to changing circumstances and demands, experiences with the current provisions, changes to relevant laws, and higher level policies will all undoubtedly create pressure for further changes. Mid-way through the ten-year review cycle, we think that the amendments made by PC1 have brought the Plan up to date.
134. The proposed plan changes represent the outcome of significant work by the Council, the community and interest groups, and we acknowledge the evident quality of the technical work and the commitment to discussion and resolution of issues outside the hearings process. Finally, we record our thanks to all those people, particularly submitters, who attended and contributed information to the hearings.



Chris Mitchell
Commissioner



Shirley Hull
Commissioner



Robert Schofield
Commissioner

SUB-MISSION #	NAME	REF	SUBJECT PROVISIONS	MATTER(S) RAISED IN SUBMISSION	SUMMARY OF DECISION(S) SOUGHT	RECOMMENDATION	DECISION & REFERENCE
1.	J W Blathwayt	1/1	Screening Standards and Derelict Vehicles, Buildings and Sites	Supports the introduction of provisions to provide a more effective means of managing identified community eyesores (eg derelict properties and vehicles).	<ul style="list-style-type: none"> Pass the changes as proposed. 	Accept	Accept Para.121
2.	D E Bray	2/1	Screening Standards and Derelict Vehicles, Buildings and Sites	Supports the introduction of provisions to provide a more effective way of managing identified community 'eyesores' (eg derelict buildings, properties and vehicles).	<ul style="list-style-type: none"> Make provision to allow Council to issue a notice for the removal, at owners cost, of derelict buildings and scrap vehicles etc. 	Accept in part	Accept in part Para.120-121 request for specific notice power rejected
3.	The NZ Transport Agency (NZTA)	3/1	Council Advisory/Warning Signs	<p>Supports, in part, the addition of a permitted activity category for advisory or warning signs erected by, or on behalf of the Council, subject to the NZTA being consulted if the advisory or warning site fronts a State Highway.</p> <p>Powerco Limited opposes decision sought.</p> <p>Introducing an advisory note will likely cause some interpretative issues if seen to apply to all the matters listed (i.e. it is beyond the scope of the plan change). The provisions are also requiring compulsory consultation. This is not appropriate. It is not clear if being informed would be sufficient to meet the standard and what happens if NZTA allege on receipt of such notice they were not properly consulted.</p>	<ul style="list-style-type: none"> Insert the following wording (underlined) into the permitted activity category, as follows: <i>advisory or warning signs erected by, or on behalf of, the Council. <u>Where an advisory or warning sign fronts State Highway, the New Zealand Transport Agency as the Road Controlling Authority shall be consulted.</u></i> 	Accept in part (subject to amendments)	Accept in part Para.83-84 Rule amended as recommended in section 42A report at 5.7.3
		FS-1				Reject	Reject
		3/2	Appendix 8 – Design of Road Access Drawing 8.1 Private Access to Primary Arterial Roads in Rural and Settlement Management Areas	Proposed diagram 8.1 is not consistent with the relevant standards and guidelines for access to a private dwelling onto a State Highway in speed environments of 70km/h or higher (i.e. outside of residential areas).	<ul style="list-style-type: none"> That Appendix 8 diagram 8.1 be replaced by the NZTA access standard Diagram C/Perspective C, or amended so that it is wholly consistent with this standard. 	Accept	Accept Para.88-89
3/3	Appendix 8 – Design of Road Access Drawing 8.2 Private Access to Primary Arterial Roads in Rural and Settlement Management Areas - Frequent Use by Heavy Vehicles	Proposed diagram 8.2 is not consistent with the relevant access standard and guidelines for access to a private dwelling onto a State Highway in speed environments of 70km/h or higher (i.e. outside of residential areas), where : <ul style="list-style-type: none"> Equivalent car movements are equal or greater to 31 per day Or where more than one slow, heavy or long vehicle movement per week is generated <p>The relevant Transport Agency standard is Diagram D/ Perspective D (attached to this submission).</p> <p>In particular, the proposed diagram does not meet the minimum standards of the Transport Agency guidelines in terms of access design and dimensions. Furthermore, the demarcated "Area to be Sealed" contains the word "Preferred" - whereas under the Transport Agency guidelines it is compulsory to seal the demarcated area to ensure the safe entry and exit of vehicles.</p>	<ul style="list-style-type: none"> That Appendix 8 diagram 8.2 be replaced by the NZTA access standard Diagram D/Perspective D, or amended so that it is wholly consistent with this standard. 	Accept	Accept Para.88-89		

SUB-MISSION #	NAME	REF	SUBJECT PROVISIONS	MATTER(S) RAISED IN SUBMISSION	SUMMARY OF DECISION(S) SOUGHT	RECOMMENDATION	DECISION & REFERENCE
		3/4	Appendix 8 – Design of Road Access Drawing 8.3 Commercial Access in Rural and Settlement Management Areas	<p>Where commercial access is to a State Highway, the proposed diagram is not consistent with the relevant Transport Agency access standards and guidelines. The relevant standard is Diagram E/ Perspective E (attached to this submission), where:</p> <ul style="list-style-type: none"> more than one slow, heavy or long vehicle movement is generated per week, and the volume of equivalent car movements generated is equal or greater than 31 per day <p>In particular, the proposed diagram does not meet the minimum standards of the Transport Agency in terms of access design and dimensions.</p> <p>Furthermore, the demarcated "Area to be Sealed" contains the word "Preferred" - whereas under the Transport Agency guidelines it is compulsory to seal the demarcated area to ensure the safe entry and exit of vehicles.</p>	<ul style="list-style-type: none"> That Appendix 8 diagram 8.3 be replaced by the NZTA access standard Diagram E/Perspective E, or amended so that it is wholly consistent with this standard. 	Accept	Accept Para.88-89
		3/5	Appendix 8 – Design of Road Access Drawing 8.4 Double Gate Access in Rural and Settlement Management Areas	<p>The key on the proposed diagram demarcated "Area to be Sealed" contains the word "Preferred". Where a double gate access is from State Highway, the Transport Agency considers it compulsory for the demarcated area to be sealed to ensure the safe entry and exit of vehicles. The requirement for sealing of the demarcated area will allow for consistency with other access types on State Highways, and ensure that risks to the safety and efficiency of the State Highway network are minimised.</p>	<ul style="list-style-type: none"> That the diagram 8.4 key be amended to the following: <i>Area to be Sealed (Preferred)</i> 	Accept	Accept Para.88-89
		3/6	Appendix 10 Performance Standards Relating to Access Spacing and Sight Distances Drawing 10.1 Performance Standards for the Physical Distance (Spacing) Between Accesses and Intersections, and Sight Distance from Accesses (Primary Arterial Roads)	<p>The figures contained within the table in proposed Appendix 10.1 do not meet the Transport Agency minimum standards in terms of sight distances, and separation distances between accesses and intersections on State Highways.</p>	<ul style="list-style-type: none"> That Appendix 10.1 is replaced by the NZTA standards: <ul style="list-style-type: none"> Diagram A/Perspective A - Accessway Sight Lines; and Diagram B/Perspective B - Accessway Separation from Intersections and Other Accessways Or amended so that the appendix is wholly consistent with these standards. 	Accept	Accept Para.88-89
4.	A Poulton	4/1	Screening Standards and Derelict Vehicles, Buildings and Sites	<p>Supports the introduction of provisions to provide the Council with a more effective means of managing identified community eyesores (eg dumped car bodies and household rubbish) that detract from the rural landscape.</p>	<ul style="list-style-type: none"> Not stated (but it is assumed that the submitter seeks that the changes, as proposed, be adopted). 	Accept	Accept Para.121

SUB-MISSION #	NAME	REF	SUBJECT PROVISIONS	MATTER(S) RAISED IN SUBMISSION	SUMMARY OF DECISION(S) SOUGHT	RECOMMENDATION	DECISION & REFERENCE
5.	Forest and Bird	5/1	Indigenous Vegetation Provisions	<p>Supports, in part, the retention of the District Plan's Policies under 2.6.4.2, and 2.6.4.2(b) and (c) in particular, as it recognises and provides for the RMA matter of national importance S6(c) "the protection of areas of significant vegetation and significant habitats of indigenous fauna". However, it is questioned whether the removal of rules in 5.5.4 is appropriate in light of the Council's obligations under RMA S6(c).</p> <p>The indigenous vegetation clearance requirements under the One Plan may not be set out in the same way as the activity based rules under the District Plan. To ensure integration between the Regional and District Council plans, and that the RPS is given effect to while still fulfilling responsibilities under the RMA, Tararua District Council will need to work with the Regional Council and landowners carrying out both permitted and consented activities under this Plan.</p> <p>It is requested that Tararua District Council sets out how it intends to do this through the inclusion of new non-regulatory methods in the District Plan, and that Schedule 3.2 in Appendix 3 is retained in the Plan and linked to these new methods.</p>	<ul style="list-style-type: none"> That the Council sets out how it will work with the Regional Council (MWRC) to ensure integration between the District and Regional Council Plans and the Regional Policy Statement, through the inclusion of new non-regulatory methods (unspecified) in the District Plan. That Schedule 3.2 in Appendix 3 of the District Plan be retained and linked to the new method(s) requested and referenced in guidance notes under appropriate rules. 	Reject	<p>Accept in part Para.94-106</p> <p>Amendments to Rule 5.2.4.3 and Sections 2.6.4.3 and 2.6.4.4 as recommended (recorded in Decision paras.99 and 101</p>
6.	Powerco Limited	6/1	Renewable Electricity Generation	<p>Supports the inclusion of additional provisions to better cater for small and community scale electricity generation in the District, but seeks the addition of some precautionary statements in the Plan regarding network connections.</p>	<ol style="list-style-type: none"> Retain the proposed amendments to adequately provide for community scale and domestic/household scale renewable energy as set out in Section 3.2.3 of Plan Change 1, without further amendment Add a note to Standard 5.3.7.2(a) along the following lines: <u>Any connection to the distribution network from a domestic scale electricity generation from a renewable energy source needs to meet the requirements of the relevant electricity service provider.</u> Retain the following proposed definitions in Part 6 Interpretation, 6.1 Definitions but add the words "via a safe connection" to the end of the new definition of "domestic scale electricity generation from renewable energy sources" so that the definitions read as follows: <u>Renewable energy has the same meaning as defined in Section 2 of the RMA.</u> <u>Domestic scale electricity generation from renewable energy sources means generating electricity on a site to meet that needs of the users of that site and includes the export from the site of any surplus electricity to a local distribution network via a safe connection.</u> Adopt any other such relief, including additions, deletions or consequential amendments necessary as a result of the matters raised in these submissions, as necessary to give effect to this submission. 	Accept in part	<p>Accept in part Para.66-71</p> <p>Note to 5.3.7.2(a) accepted as recommended in section 42A report at 5.2.3.1</p>

SUB-MISSION #	NAME	REF	SUBJECT PROVISIONS	MATTER(S) RAISED IN SUBMISSION	SUMMARY OF DECISION(S) SOUGHT	RECOMMENDATION	DECISION & REFERENCE
		6/2	Hazardous Substances	Supports deletion of the Hazardous Substances and Contaminated Land provisions and reliance on HSNO and NES for Assessing and Managing Contaminants in Soil to Protect Human Health Regulations 2011.	<ol style="list-style-type: none"> 1. Retain the proposed amendments to remove overlapping functions for hazardous substances and contaminated land management, as set out in Section 3.3.3 of Plan Change 1, without further amendment. 2. Adopt any other such relief, including additions, deletions or consequential amendments necessary as a result of the matters raised in these submissions, as necessary to give effect to this submission. 	Accept	Accept Para.72-77 Minor amendments under clause 16(2) made at para.77
		6/3	Indigenous Vegetation Provisions	Supports the giving of effect to the One Plan RPS provisions on significant indigenous vegetation and habitats by ensuring district provisions are limited to controls based on amenity reasons.	<ol style="list-style-type: none"> 1. Retain the proposed amendments to more appropriately target the provisions relating to indigenous vegetation and habitats and remove duplication and inconsistency with the One Plan as set out in Section 4.1.3 of Plan Change 1, without further amendment. 2. Adopt any other such relief, including additions, deletions or consequential amendments necessary as a result of the matters raised in these submissions, as necessary to give effect to this submission. 	Accept	Accept in part Para. 94-106 Amendments to Rule 5.2.4.3 and Sections 2.6.4.3 and 2.6.4.4 as recommended (recorded in Decision paras.99 and 101.
		6/4	Natural (Flood) Hazards	Supports the reasoning and rationale of the approach being taken by the Council.	<ol style="list-style-type: none"> 1. Retain the proposed amendments to Natural (Flood) Hazard provisions as set out in Section 4.3.3 of Plan Change 1, without further amendment. 	Reject	Accept in part Para.108-114 Amendments to Section 6.1, Section 5.1.7.1, and advisory note to 5.1.7 accepted as recommended in section 42A report 5.6.3 (a), (b) and (d).
7.	Federated Farmers of New Zealand	7/1	National Environmental Standard for Telecommunication Facilities (2008)	Supports the addition of a reference to the NES in the District Plan.	Adopt the change as notified.	Accept	Accept Para.78 Minor amendments changing 2008 to 2016 under clause 16(2) made at para.79

SUB-MISSION #	NAME	REF	SUBJECT PROVISIONS	MATTER(S) RAISED IN SUBMISSION	SUMMARY OF DECISION(S) SOUGHT	RECOMMENDATION	DECISION & REFERENCE
		7/2	National Policy Statement for Renewable Electricity Generation 2011 (NPSREG)	<p>Supports, in part, the need to provide for small and community scale renewable electricity generation in the Plan as required by NPSREG. Clarification is sought that the approach taken by the Council to the new permitted activity standard allows for energy generation from renewable energy sources not just for homes in the district but to support farming and other primary production infrastructure.</p> <p>Powerco Limited opposes in part and Supports in part. Powerco is supportive of providing for NPSREG, however it is not considered necessary to define the purpose for which power will be used. Power generated on a site should be able to be used on the site. Powerco is also mindful of the need for all community scale and domestic/household scale electricity generation connections to be safe and to meet Powerco's standards. Powerco, through its own submission, seeks to ensure a suite of precautionary statements are included within the Plan to ensure safe connections. Powerco supports the definitions of the NSPREG being adopted.</p>	<ul style="list-style-type: none"> Amend Rule 5.3.7.2(a) to include electricity generation from renewable energy sources for farming and primary production as a permitted activity, in keeping with the intention of the NPSREG 2011. Amend the terminology (definition of) 'domestic scale electricity generation from renewable energy sources' to better account for small and community scale uses such as the powering of primary production activities. 	<p>Reject</p> <p>Reject</p> <p>Accept in part</p>	<p>Reject Para.66-71</p> <p>Reject Para.66-71</p> <p>Accept in part</p>
		7/3	Hazardous Substances	<p>Supports the view that additional and more specific controls in the District Plan are no longer necessary in light of the changed statutory environment relating to hazardous substances. Any rules in a District Plan are now unnecessary duplication and difficult for Council's to enforce.</p>	Adopt the changes as notified.	Accept	<p>Accept Para.72-77 amendments under clause 16(2) made at para.77</p>
		7/4	Indigenous Vegetation Provisions	<p>Supports the Council's intention to remove the rules in the District Plan relating to indigenous vegetation, and the schedule of significant indigenous vegetation and significant habitats of indigenous fauna, in keeping with the policy direction of the Horizon's Regional Council One Plan.</p>	Adopt the changes as notified.	Accept	<p>Accept Para.94-106 Amendments to Rule 5.2.4.3 and Sections 2.6.4.3 and 2.6.4.4 as recommended (recorded in Decision paras.99 and 101.</p>
		7/5	Minimum Lot Sizes for Wastewater Disposal	<p>The intention to ensure the District Plan is consistent with the One Plan is supported but concern is expressed at the removal of the option for a drainage easement over adjacent land as a means of compliance with the standard. The current Rule [5.1.2.2(c)(i)] provides landowners with greater flexibility, such as where a home is carved off from a farm. Federated Farmers opposes the removal of this provision from the District Plan and suggests that Horizons and the District Council engage in further conversation as to how it can be retained.</p>	<ul style="list-style-type: none"> Adopt the advisory text as notified. Retain the reference to a drainage easement in Rule 5.1.2.2(c)(i) in the District Plan. 	Accept	<p>Accept Para.80-82</p>

SUB-MISSION #	NAME	REF	SUBJECT PROVISIONS	MATTER(S) RAISED IN SUBMISSION	SUMMARY OF DECISION(S) SOUGHT	RECOMMENDATION	DECISION & REFERENCE
		7/6	Natural (Flood) Hazards	Supports the Council's approach to flood mapping; namely that until more accurate modelling is complete there is no reason to change the current flood mapping. The inclusion of the proposed 'Introduction' wording is supported.	Adopt the proposed introductory text as notified.	Accept in part	Accept in part Para.108-114 Amendments to Section 6.1, Section 5.1.7.1, and advisory note to 5.1.7 accepted as recommended in section 42A report 5.6.3 (a), (b) and (d).
		7/7	Earthworks	Supports the intention to increase the volume of earthworks within the Rural Management Area from 200m ³ to 1,000m ³ and therefore remove unreasonable restrictions. This better reflects the requirements for earthworks in the rural zone.	Adopt the changes as notified.	Accept	Accept Para.86-87
		7/8	Screening Standards and Derelict Vehicles, Buildings & Sites	Supports, in part, the intention to appropriately maintain and enhance amenity. However, concern is expressed that the proposed provisions will capture farm buildings such as old sheds, and therefore could render farmers' activities as non-compliant with the Plan. Farm buildings and infrastructure re designed for practical purposes and are not built or maintained with beauty in mind, therefore introducing standards around amenity, character and appearance is difficult and subjective. The introduction of a lot size is suggested, so that the proposed provisions only apply to sites under two hectares.	Address the issues raised in this submission point through consideration of more objective standards; and amend so that the provisions only apply to sites under 2 hectares.	Reject	Accept in part Para.116-119,121 request to restrict rule to Rural sites <2ha rejected
		7/9	Updating and Minor Corrections of Existing Plan Provisions	Supports the updating of incomplete references and wording changes.	Adopt the changes as notified.	Accept	Accept Para.90-91
8.	Manawatu-Wanganui Regional Council (Horizons)	8/1	Renewable Electricity Generation	Supports the proposed changes to standard 5.3.7.2(a).	That the proposed changes to Standard 5.3.7.2(a), following the 'Note' on page 5 – 66, be retained as drafted in PPC1.	Accept	Accept Para.66-71
		8/2	Hazardous Substances	Supports, in general, the proposed amendments to Section 5.1.8 of the District Plan but reservations are expressed concerning the extent of the amendments and their timing.	<ul style="list-style-type: none"> That TDC consider retaining some control over land use to address adverse effects of the storage, use or transport of hazardous substances in relation to (but not limited to) sensitive areas and activities, land prone to natural hazards, or reverse sensitivity. Provide any alternative relief that gives effect to the One Plan policies for management of hazardous substances. 	Accept in part	Accept in part Para.72-77 Minor amendments under clause 16(2) made at para.77
		FS-1		Powerco Limited opposes decision sought. Powerco supports the removal of provisions that duplicate controls (e.g. under HSNO Act and Health and Safety at Work Act). It is unclear on what basis (i.e. no supporting S32 analysis) hazardous substances need to be further controlled in this District.		Accept	Accept

SUB-MISSION #	NAME	REF	SUBJECT PROVISIONS	MATTER(S) RAISED IN SUBMISSION	SUMMARY OF DECISION(S) SOUGHT	RECOMMENDATION	DECISION & REFERENCE
		FS-2		<p>The 'Oil Companies' oppose decision sought.</p> <p>The 'Oil Companies' support the removal of provisions that duplicate controls (e.g. under HSNO Act and Health and Safety at Work Act). It is unclear on what basis (i.e. no supporting S32 analysis) hazardous substances need to be further controlled in this District.</p>		Accept	Accept
		8/3	Indigenous Vegetation Provisions	<p>Supports the proposed changes to the Section 2.6.4.3 explanation, the 2.6.4.4 methods, the Section 5.5.1 introduction, the heading for Rule 5.5.3.2 and Table One in Rule 5.5.3.4, and the deletion of Rule 5.5.4 and Schedule 3.2 in Appendix 3. It is considered that all of these proposed changes will give effect to One Plan Policy 6-1.</p> <p>Concern is expressed that the current District Plan provisions do not fully give effect to One Plan Policy 6-6, concerning the spatial definition of regionally outstanding natural features and landscapes.</p>	<ul style="list-style-type: none"> That the rules in Section 5.5.4 and Schedule 3.2 of Appendix 3 be deleted from the District Plan as proposed in PPC1. That the proposed changes set out in Section 4.1.3 of the Plan Change document be retained as drafted. Provide any alternative relief to give effect to the One Plan policy framework for maintaining and enhancing indigenous biological diversity. 	Accept	Accept Para.94-106
		8/4	Minimum Lot Sizes for Wastewater Disposal	<p>Supports, in general, the proposed changes, subject to minor wording changes and is neutral with respect to the deletion of the statement in Rule 5.1.2.2(c)(i) that allows for drainage easements as a means of achieving compliance with the domestic wastewater standards.</p>	<ul style="list-style-type: none"> That the advisory note following clause (b) of Subdivision Standard 5.2.3.2 be retained, subject to removal of the word 'Proposed' that precedes the 'One Plan.' That the proposed advisory note to be added to Rule 5.1.2.2(c)(i) be retained as drafted, subject to a minor amendment to include the word "likely" after "will," as follows: <i>"Note: Where an area of land of less than 5,000m² is to be used to build a dwelling with associated domestic wastewater disposal, a resource consent will likely be required from MWRC prior to the installation of the wastewater disposal system and for any future upgrades to that system. The Council will require sufficient information to be presented to it to demonstrate that the site will be able to properly dispose of effluent within its boundaries in compliance with the requirements of One Plan Rule 14-14 and the Manual for Onsite Wastewater Systems Design and Management (Horizons Regional Council, 2010)."</i> 	Accept	Accept Para.80-82
		8/5	Natural (Flood) Hazards	<p>A view is expressed that PPC1 does not give effect to One Plan Policy 9-1(c) and does not provide TDC with the ability to control land use activities in flood prone areas in accordance with Policy 9-2. The proposal to delay the inclusion of known floodable areas on the District Plan Maps and flood hazard provisions in the District Plan until the completion of additional flood modelling through the Hazards Upgrade project is also not supported.</p>	<ul style="list-style-type: none"> That a definition of "natural hazard areas" be added to the District Plan that references those areas known to be at risk of inundation in a 0.5% AEP flood. Possible wording is as follows: <ul style="list-style-type: none"> "Natural Hazard Area (Flooding) means Land at risk of inundation during a 0.5% Annual Exceedance Probability (1 in 200 year) flood event." Provide any alternative relief to give effect to the One Plan policy framework to manage development in areas prone to flooding. That an advice note be included for plan users to encourage plan users to contact Horizons for coastal hazard information. 	Accept in part (subject to amendments)	Accept in part Para.108-114 Amendments to Section 6.1, Section 5.1.7.1, and advisory note to 5.1.7 accepted as recommended in section 42A report 5.6.3 (a), (b) and (d).

SUB-MISSION #	NAME	REF	SUBJECT PROVISIONS	MATTER(S) RAISED IN SUBMISSION	SUMMARY OF DECISION(S) SOUGHT	RECOMMENDATION	DECISION & REFERENCE
		FS-1		<p>Powerco Limited opposes decisions sought.</p> <p>On the ground of uncertainty - it is important to ensure that any proposed provisions do not hinder / restrict the maintenance and / or upgrading of existing Powerco assets or unnecessarily impede the development of new assets. Adopting the proposed submission by Horizons would require changes outside the scope of the Plan Change to ensure network utilities are not fettered.</p> <p>In their submission Horizons raise Rangitikei District Council as an example. It is important to note that their approach was built on a suite of complementary provisions that ensures that electrical lines are not inadvertently fettered (via a stand-alone utilities section - B1.12).</p>		Reject	Reject
		8/6	Updating of Outdated References	<p>Supports the proposed changes in Section 6.4.3 of the PPC1 that seek to amend outdated references to Horizons' Regional Policy Statement and Plans and the Proposed One Plan, and recommends that they be retained as drafted.</p>	<ul style="list-style-type: none"> That the changes proposed in Section 6.4.3 of PPC1 be retained as drafted. 	Accept	Accept Para.90-91
9.	Z Energy Limited, Mobil Oil NZ Limited, and BP Oil NZ Limited (the "Oil Companies")	9/1	Hazardous Substances	<p>Supports the amendments proposed to address the deletion of the Hazardous Substances and Contaminated Land provisions and place reliance on HSNO and the NES (Soils) Regulations.</p>	<ol style="list-style-type: none"> Retain the proposed amendments to remove overlapping functions for hazardous substances and contaminated land management as set out in Section 3.3.3 of Plan Change 1, without further amendment. Adopt any other such relief, including additions, deletions or consequential amendments necessary as a result of the matters raised in these submissions, as necessary to give effect to this submission. 	Accept	Accept Para.72-77 Minor amendments under clause 16(2) made at para.77



District Plan Proposed Plan Change No.1

Decisions Version of Proposed Changes

The following decisions are based on the changes proposed to the District Plan as described and referenced in Proposed Plan Change 1 as publicly notified:

3.1.3 Proposed Change(s)^{1,2} - NES for Telecommunication Facilities

- .1 THAT the following paragraph be added to the 'Introduction' section on page 5-61;
"The Resource Management (National Environmental Standards for Telecommunication Facilities) Regulations 2016 apply to telecommunication facilities generating radiofrequency fields and to those located in road reserves. They also place controls on antennae, utility structures, cabinets and noise emissions and conditions designed to protect trees, vegetation, historic heritage values, amenity values and the coastal marine area. These regulations take precedence over the District Plan's provisions and must be considered if the activity involves or affects any of the abovementioned matters."
- .2 THAT the following words be added to the introductory note following the heading '5.3.6.2 Standards' on page 5-61:
"... network utilities, and to the Resource Management (National Environmental Standards for Telecommunication Facilities) Regulations 2016 or successor.]"
- .3 THAT rule 5.3.6.2(a)(v) on page 5-62 be amended to read as follows:
"(v) Line(s) as defined in section 5 of the Telecommunications Act 2001."

3.2.3 Proposed Change(s) - NPS for Renewable Electricity Generation 2011

- .1 THAT Standard 5.3.7.2(a), on page 5-66, be amended to read as follows:
"(a) Permitted activities in all Management Areas
 - *The operation and maintenance of ~~renewable electricity~~ facilities generating electricity from renewable energy sources including wind farms, in existence as at the date this Plan became operative."**"[Note: Any connection to the distribution network arising from domestic scale electricity generation from a renewable energy source must meet the requirements of the relevant electricity service provider and specific electricity sector legislation]."*
- .2 THAT the following permitted activity be added to Standard 5.3.7.2(a) following the 'Note' on page 5 - 66, as follows:
"- Domestic scale electricity generation from renewable energy sources subject to meeting the following performance criteria:
 - (i) the facility generating the electricity meets all the applicable amenity standards for permitted activities in section 5.4 of this Plan;*
 - (ii) the facility generating the electricity is not located on land identified as a scheduled heritage feature including its curtilage."*
- .3 THAT the following definitions be added to Part 6 Interpretation, 6.1 Definitions, in alphabetical order, as follows:
"- Renewable energy has the same meaning as defined in Section 2 of the RMA."
"- Domestic scale electricity generation from renewable energy sources means generating electricity on a site to meet the needs of the users of that site and includes the export from the site of any surplus electricity to a local electricity distribution network."

¹ Proposed new text is shown underlined; text to be ~~deleted~~ is shown as ~~strikethrough~~

² Changes made by decision, post notification, are **highlighted**

3.3.3 Proposed Change(s) - Hazardous Substances

- .1 THAT section 5.1.8.1 Introduction text (pages 5 - 22 and 5 - 23) be deleted and replaced with the following:

“5.1.8.1 Introduction

Numerous agencies share overlapping responsibilities for controlling the use storage, transportation and disposal of hazardous substances and managing contaminants in the environment. Their statutory functions and responsibilities are derived from the following statutes and regulations:

- Hazardous Substances and New Organisms Act 1996 and related Regulations (HSNO).
- Health and Safety at Work Act 2015 and Regulations relating to hazardous substances (HSWA).
- Resource Management Act 1991 (RMA).
- Resource Management (National Environmental Standard for Assessing and Managing Contaminants in Soil to Protect Human Health) Regulations 2011 (NES Soils).

In terms of the latter (the NES Soils), these regulations are administered by the Council and relate directly to the Council’s S31(1)(b)(iii) RMA function, namely “... the prevention or mitigation of any adverse effects of the development, subdivision, or use of contaminated land:”

The NES Soil regulations apply when a person wants to carry out an activity specified in the regulations, on land as described in the regulations which is contaminated or potentially contaminated.

The activities covered in the regulations include removing or replacing a fuel storage system, soil sampling (to determine if the soil is contaminated or not), soil disturbance for a particular purpose, subdividing land or changing the use of the land where such change of use could be harmful to human health, on land that is described in the Ministry for the Environment’s Hazardous Activities and Industries List (commonly referred to as HAIL).

In terms of the former statutes (the HSNO and HSWA Acts), the HSNO Act will continue to be the primary legislation for the regulation of hazardous substances. Administered by the Environmental Protection Authority (EPA) the HSNO regulatory regime is responsible for:

- assessment and approval of all hazardous substances;
- classifying all hazardous substances;
- setting controls (EPA controls) that apply to all hazardous substances, including controls for labelling, material safety data sheets (MSDS), and disposal;
- setting content controls (i.e. allowable levels of hazardous substances) for substances that affect human health and safety and the environment (e.g. cosmetics, domestic cleaning products, and pesticides);
- setting controls for hazardous substances that adversely affect the environment;
- setting controls for hazardous substances that affect human health and safety used outside the workplace; and

Worksafe New Zealand, through the HSWA's regulatory regime, is primarily responsible for regulating substances that affect human health and safety within the workplace, including:

- incorporating or referring to EPA controls, where appropriate;
- setting controls on the use, handling, generation, and storage of hazardous substances at the workplace;
- quality assurance mechanisms, e.g. test certification; and
- generally regulating such substances within the legislative framework for work health and safety.

The HSWA (S212) enables regulations relating to hazardous substances to be implemented for a number of purposes, including (inter alia):

- prescribing controls to avoid or mitigate illness or injury to people or damage to the environment or chattels from any hazardous substance:
- prescribing requirements to manage any emergency involving a hazardous substance:
- prescribing systems for tracking hazardous substances, including requirements that—
 - (i) the whereabouts of the substances be recorded at all times or from time to time:
 - (ii) the quantity of the substances be recorded:
 - (iii) a person be identified as being in charge of the substances:

When these HSNO and HSWA responsibilities are combined with the responsibility of the Regional Council to manage hazardous substances and the discharge of contaminants into the environment, the Council considers there is no need or justification to provide any further regulations (rules) or other provisions in the District Plan in order to exercise its RMA S31(1)(b) functions."

- .2 THAT standards (rules) 5.1.8.2, 5.1.8.3 and 5.1.8.4 (pages 5-23 to 5-25) be deleted.
- .3 THAT Method 2.9.4.4(a) on page 2-84 be deleted and replaced with the following:
“(a) District Plan Rules – None.”
- .4 THAT the Reasons section 2.9.4.5 of Policy 2.9.4 Hazardous Substances (pages 2-84 and 2-85) be amended, as follows:

“Numerous agencies share overlapping responsibilities for controlling the use, storage, transportation and disposal of hazardous substances. The Hazardous Substances and New Organisms Act 1996 (HSNO) is the primary legislation controlling hazardous substances. The Environmental Risk Management Authority (ERMA) is responsible for implementing, administering and monitoring the enforcement of the HSNO Act. Both the HSNO Act and the RMA are designed to protect human health and the environment from the effects of hazardous substances and to work in conjunction with one another. The HSNO Act aims to manage the intrinsic risks of hazardous substances and the end use, export or disposal of such substances and applies to all hazardous substances. In other words, the HSNO Act sets “the bottom line” in terms of the standards that must be met in relation to hazardous substances. It is the responsibility of Regional and District Councils, under the RMA, to determine whether more stringent controls are also necessary (in addition to the provisions of the HSNO Act) in terms of the control of the use of the land in the region for the use, transport, storage and disposal of hazardous substances. Pursuant to section 62(1)(i) of the RMA, the MWRC's Regional Policy Statement and Proposed One Plan stipulate that the Regional Council will have responsibility for controlling the use of land for the disposal of

hazardous substances and the District Council will have responsibility for the control of land for the use, storage and transport of hazardous substances.

Their statutory functions and responsibilities are derived from a number of statutes and regulations. [These agencies and their responsibilities are described in the Introduction (5.1.8.1) of Section 5.1.8 Hazardous Substances of this Plan].

When the responsibilities of these statutory bodies are combined with the responsibilities of the Regional Council to manage hazardous substances and the discharge of contaminants into the environment, the Council considers there is no need or justification to provide any further regulations (rules) or other provisions in the District Plan in order to exercise its RMA S31(1)(b) functions."

4.1.3 Proposed Change(s) - Indigenous Vegetation Provisions

- .1 THAT Policy Sections 2.6.4.3 Explanation and 2.6.4.4 Methods, on pages 2-53 and 2-54, be amended as follows:

"Additionally, significant trees of the District have been scheduled in Appendix 3 of this Plan. The MWRC's ~~Proposed One Plan~~ states that the District Council shall, in addition to implementing the stated objectives and policies in respect of biodiversity management in the ~~Proposed One Plan~~, "retain schedules of notable trees and amenity trees" in the District Plan. This is necessary because the ~~Proposed One Plan~~ uses a region wide approach and includes a schedule of regionally outstanding landscapes and identifies at risk and threatened species and habitats, but does not include specific provisions for significant trees in each District within the Region. Similarly, specific landscapes within the Region warrant specific management, and where appropriate, protection in the District Plan, in addition to the provisions of the ~~Proposed One Plan~~."

The MWRC, in its ~~Proposed One Plan~~, has ~~stated that it will~~ taken the lead role in managing indigenous biodiversity in the Region. The ~~Proposed One Plan~~ includes rules that control activities in rare and threatened habitats and at risk habitats. It ~~will is~~ therefore be unnecessary for the District Plan to include these rules as well. The ~~Proposed One Plan~~ also states that the Regional Council will work with landowners to ~~maintain or protect and enhance these the [rare and threatened and at risk] habitats~~". ~~It is therefore important that the District Plan not be inconsistent with the objectives and policies of the Proposed One Plan and that the Council give effect to the Regional Council's policy (RPS) in respect of the management of biodiversity once this has been determined by due process. However, given the time necessary for the provisions of the Proposed One Plan to be considered and determined, it will be necessary to retain the current provisions in the District Plan relating to biodiversity, particularly Rule 5.5.4.~~

Whilst the Regional Council takes primary responsibility for maintaining indigenous biological diversity in the District, by using (inter alia) rules to control the use of land to protect areas of significant indigenous vegetation and habitat, the Council will continue to exercise its responsibilities in relation to any matters not regulated by the Regional Council such as when considering and determining resource (land use and subdivision) consent applications. It will work closely with the Regional Council to ensure that Policy 6-1 of the Operative One Plan is implemented in a consistent and effective manner as detailed in method (a) of 2.6.4.4 Methods.

Policies 2.6.4.2(d) and (e) aim to assist landowners in the management of indigenous biodiversity on private land and to support the efforts of the Regional Council, landowners, and other agencies (such as the QEII Trust) in the management of indigenous biodiversity.

2.6.4.4 Methods:

The Council shall implement policies 2.6.4.2 (a), (b) and (c) by the following methods:

- (a) *District Plan and resource consents - The Council has included in this District Plan, in Appendix 3, a Schedule of Significant Trees, ~~a Schedule of Significant Indigenous Vegetation and Significant Habitats of Indigenous Fauna~~, and a Schedule of Natural Features and Landscapes, and has adopted rules which aim to control the adverse effects of activities at, or in close proximity to these listed items. The Schedules classify the items as Category A or B according to their significance and*

the level of protection required. The scheduled significant trees, ~~significant indigenous vegetation and significant habitats of indigenous fauna~~ and natural features and landscapes are identified on the District Plan maps.

[Refer to Part 9 of the Plan].

In respect of resource consent enquiries and processing, the Council shall work with the Regional Council to recognise and provide for S6(c) of the RMA and achieve consistent implementation of the respective Councils' functions for the maintenance of indigenous biological diversity. In particular, the Council shall consult with the Regional Council when land use or subdivision consent applications are being considered which may, were consent to be granted, have adverse effects on indigenous vegetation or habitats.

~~The Council has also included a set of provisions for the protection of unscheduled areas of significant indigenous vegetation. These provisions will enable an activity in an unscheduled area to be assessed on a case by case basis in order to establish whether the vegetation concerned is "significant" and, if it is significant, whether or not it should be protected.~~

(b) Public consultation and the provision of information and promotion of voluntary protection - The Council shall consult with relevant groups and organisations in the community to identify natural features of value to the community. With respect to the majority of the District which lies within the Manawatu-Wanganui Region, the ~~Proposed One Plan's~~ Regional Policy Statement states that the Regional Council will act as lead agency in preparing inventories of areas of significant indigenous flora and habitats of indigenous fauna."

- .2 THAT Section 5.5.1 Introduction (pages 5 – 100 to 5 – 102) be amended as follows:
- amend the third bullet point on page 5 – 100 as follows:
 - ~~significant vegetation and habitats (including individual trees and groups of trees; areas of significant indigenous vegetation and habitats of indigenous fauna);~~
 - Delete all the text from and including the heading "INDIGENOUS VEGETATION PROVISIONS" on page 5 – 101 to before the heading '5.5.2 CLASSIFICATION OF SCHEDULED FEATURES' on page 5-102 and replace it with the following:
- "In accordance with Policy 6-1 of the MWRC's One Plan, the Regional Council is responsible for developing objectives, policies and methods (including rules) for maintaining and protecting areas of significant indigenous vegetation and significant habitats of indigenous fauna throughout the Region, including the Tararua District."*
- .3 THAT the heading for Rule 5.5.3.2 (page 5 – 103) be amended as follows:
- ~~"5.5.3.2 Significant Trees, Significant Indigenous Vegetation and Significant Habitats of Indigenous Fauna (as listed in Schedules 3.1 and 3.2 in Appendix 3)"~~
- .4 THAT Table One in Rule 5.5.3.4 (page 5 – 105) be amended as follows:

SIGNIFICANT TREES, SIGNIFICANT INDIGENOUS VEGETATION, OR SIGNIFICANT HABITAT OF INDIGENOUS FAUNA (Schedules 3.1 and 3.2 in Appendix 3)	Permitted Maintenance Discretionary Modification Non-complying Damage or destruction	Permitted Maintenance Discretionary Modification, damage or destruction
--	--	---

- .5 THAT Rule 5.5.4, pages 5 – 110 to 5 – 114 inclusive, be deleted from the District Plan.
- .6 THAT Schedule 3.2 in Appendix 3 (pages A-25 to A-32 inclusive) be deleted from the District Plan.

.7 Add a matter for control under Land Subdivision Rules: Subdivision Standards: Classification of Activities: Section 5.2.4.3 - 'Matters over which the Council reserves control in relation to controlled activities' to read:

"In respect of the controlled activities listed in 5.2.4.2 above, the matters over which the Council shall exercise control by the imposition of conditions are:

...

(g) the measures necessary to avoid or mitigate adverse effects on indigenous biodiversity, including those required to protect vegetation and habitat consistent with this Plan's 2.6.4.2 Policies.

4.2.3 Proposed Change(s) - Minimum Lot Sizes for Wastewater Disposal

- .1 THAT the following sentence be retained in the first paragraph of Rule 5.1.2.2(c)(i) on page 5-3:

"A drainage easement over adjacent land shall be an acceptable means of compliance with this standard where there is insufficient area of land within the Certificate of Title concerned."

- .2 THAT the following advisory note be added to Rule 5.1.2.2(c)(i), following the second paragraph:
"Note: Where an area of land of less than 5,000m² is to be used to build a dwelling with associated domestic wastewater disposal, a resource consent will likely be required from MWRC prior to the installation of the wastewater disposal system and for any future upgrades to that system. The Council will require sufficient information to be presented to it to demonstrate that the site will be able to properly dispose of effluent within its boundaries in compliance with the requirements of One Plan Rule 14-14 and the Manual for Onsite Wastewater Systems Design and Management (Horizons Regional Council, 2010)"

- .3 THAT the advisory note following clause (b) of Subdivision Standard 5.2.3.2 (Page 5-29) be retained, subject to removal of the word 'Proposed' that precedes the words 'One Plan'.

4.3.3 Proposed Change(s) - Natural (Flood) Hazards

- .1 THAT Section 5.1.7.1 Introduction on page 5-20 be deleted and replaced with the following:

"5.1.7.1 Introduction

In order to achieve the objectives and policies contained within Section 2.5 of this District Plan, a number of rules have been developed to control the use of land to avoid, remedy or mitigate the adverse effects of natural hazards.

Policy 9-1 of the Manawatu-Wanganui Regional Council's One Plan sets out the responsibilities for hazard management within the Region. For the Tararua District Council, these responsibilities include:

(i) developing objectives, policies and methods (including rules) for the control of the use of land to avoid or mitigate natural hazards in all areas and for all activities except the following (which are Regional Council responsibilities):

- all land use activities in the coastal marine area,*
- erosion protection works that cross or adjoin mean high water springs,*
- all land use activities in the beds of rivers and lakes, for the purpose of avoiding or mitigating natural hazards.*

(ii) identifying floodways (as shown in Schedule J1 of the One Plan) and other areas known to be inundated by a 0.5% annual exceedance probability (AEP) flood event on planning maps in district plans, and controlling land use activities in these areas in accordance with Policies 9-2 and 9-3 of the One Plan.

None of the floodways as shown in Schedule J1 of the One Plan are within the Tararua District.

Policy 9-2(b) of the One Plan states that TA's must not allow the establishment of any new structure or activity, or an increase in the scale of any existing structure or activity, within an area which would be inundated in a 0.5% AEP flood event unless:

(i) flood hazard avoidance is achieved or the 0.5% AEP (1 in 200 year) flood hazard is mitigated, or

(ii) the non-habitable structure or activity is on production land, or

(iii) there is a functional necessity to locate the structure or activity within such an area

The District Plan contains provisions that limit development in recognised natural hazard areas in order to reduce risk to human life, property and infrastructure. Rule 5.1.7.2 applies to the Natural Hazard Areas that are identified on the planning maps. No areas are currently identified on the maps.

"The District Plan does however contain a series of maps at a scale of 1:50,000 which identify areas of land that could potentially be adversely affected by flooding or surface flooding. Areas affected by poor drainage are also shown as floodable areas. These maps have been prepared using a variety of sources such as photographs of and reports about flood events, anecdotal information and field visits. They have not been prepared using data modelling to identify areas of land likely to be inundated by a 0.5% annual exceedance probability (AEP) flood event. They are indicative only and have been prepared solely for the purpose of showing areas in which the nature, extent and risk of flooding requires further investigation prior to any subdivision, development or change in land use occurring.

In addition to these District Plan 'Flood Maps', the Council is also able to consider Natural Hazard Area (Flooding) information (the 0.5% AEP flood modelling) provided by the Manawatu-Wanganui Regional Council for the Upper Gorge (including Woodville), Mangatainoka, Pahiatua and Herbertville. One in 100 year (1% AEP) flood modelling information, in respect of coastal inundation at Akitio, is also able to be referenced. When considering applications for building permits, subdivision of land or changes of use the Council will consider all the above-mentioned information and take this in to account in the decision making process.

Persons intending to develop or purchase a property within an area identified by the Council as being floodable, will be advised to contact the Manawatu-Wanganui Regional Council (Horizons) for assistance in obtaining more detailed, site-specific information.

The Regional Council's Long Term Plan makes provision for a number of hazards information projects to be carried out in the Tararua District, over a period of 6 years, including 0.5% AEP flood modelling. Once these information gathering projects have been completed it ought to be possible to identify the areas at risk of inundation in a 0.5% AEP event on the District Planning maps and therefore become subject to Rule 5.1.7.2".

- .2 Add the following advisory note to Section 5.1.7 Natural Hazards, on page 5-22, immediately following criterion (e):

Note: In order to meet the requirements of 5.1.7.4(d) and 5.1.7.5(a), persons wanting to change or intensify a land use, subdivide land or erect or extend any building or structure in an area identified as being floodable or within 1 kilometre of the District's coastline, are advised to contact the Manawatu-Wanganui (Horizons) Regional Council for assistance and/or advice in respect of any detailed, site-specific hazard risk related thereto.]

- .3 Add the following definition to Section 6.1 of the District Plan, on page 6-7, immediately above the definition of 'Network Utility':

"Natural Hazard Area (Flooding) means Land at risk of inundation during a 0.5% Annual Exceedance Probability (1 in 200 years) flood event."

5.1.3 Proposed Change(s) - Council Advisory/Warning Signs

- .1 THAT a further permitted activity category be added to Rule 5.4.3.2(b) on page 5-78, as follows:

"viii) Advisory or warning signs erected by, or on behalf of, the Council except where such signs front State Highway in which case the written approval of the New Zealand Transport Agency, as the Road Controlling Authority, is required for such signs to be deemed a permitted activity".

5.2.3 Proposed Change(s) - Off-Site Signs Rules

THAT a further performance standard be added to Rule 5.4.3.2(d)(iv) on page 5-80, as follows:

"• Written notice has been provided to the Council, advising details of the size, location and content of the sign, its planned date of construction and expected date of completion."

5.3.3 Proposed Change(s) - Earthworks Rules

THAT the references to "200m³" in Rule 5.1.5.2(b)(i) and 5.1.5.2(b)(ii) be replaced with "1,000m³".

5.4.3 Proposed Change(s) - Outdoor Living Courts

THAT Rule 5.4.5.2(c) be amended as follows:

"(c) the outdoor living court shall be unoccupied and unobstructed from the ground upwards, provided except that structures designed to enhance the use and enjoyment of the outdoor living court (e.g. garden structures, garden furniture, pergolas), ~~and~~ eaves and upper storey projections not exceeding 0.6 metres, and decks at ground level or on a downwards sloping outdoor living court site where the deck is at the same level or lower than the ground floor of the dwelling house are permitted;"

5.5.3 Proposed Change(s) - Screening Standards and Derelict Vehicles, Buildings and Sites

- .1 THAT section 2.6.2.5 Reasons, on page 2-45, be amended as follows:

"Potential effects include, amongst other things, noise, dust, smoke, vibration, glare, odour and visual effects (including, for example, those arising from the presence of derelict vehicles, buildings and sites)."

.2 THAT a new section 5.4.12 be added, on page 5-99 following 5.4.11.4(a), as follows:

“5.4.12 LOCAL EYESORES (DETRIMENTS TO AMENITY VALUES)

5.4.12.1 Introduction

Throughout the District, derelict buildings, vehicles and sites which are unsightly and widely considered to be community eyesores can be deemed to be detracting from "amenity values". One of the primary objectives of the District Plan is "to ensure a high level of environmental quality and amenity" in both the urban and rural areas of the district (see objectives 2.2.4.1 and 2.3.4.1). The provisions of the Plan seek to achieve a balance between maintaining the amenity values of an area in the public interest and not unduly constraining the property rights of individuals to develop their own sites in an environmentally acceptable manner. This is a fine balance and a qualitative one, in the sense that one person's eyesore may be another person's 'thing of beauty'. That being the case, the following standards are designed to give effect to Objectives 2.2.4.1 and 2.3.4.1 and limit the extent to which derelict buildings, vehicles and sites may become community eyesores.

5.4.12.2 Standard

Any activity permitted by this Plan, in any Management Area, is only permitted provided the activity is not carried out on a derelict site.

[Note: see the definition of 'derelict site' in this Plan]

5.4.12.3 Non-Compliance with Standard

Where an activity cannot meet the standard specified in 5.4.12.2 above, the activity shall be deemed to be a discretionary activity, requiring resource consent. An application for such a consent shall be publicly notified.

5.4.12.4 Criteria for Assessment

In addition to the criteria specified in section 7.3.10(a) of this Plan, the Council shall have regard to the following in respect of any application under 5.4.12.3 above for a discretionary activity:

- (c) the degree and significance of any adverse effect on the amenity values of the locality;
- (d) the existence of any proposed screening and/or landscape treatment plan (including suitability of materials/plants, screening potential, timeframe for implementation, maintenance programme);
- (e) any other avoidance or mitigation measures proposed.

.3 THAT a definition of 'derelict site' and 'derelict vehicle' be added to Section 6.1 Definitions on page 6-2 after 'Crossing Place', as follows:

"Derelict site" means any land which detracts, or is likely to detract, to an observable, significant degree from the amenity, character or appearance of land in the neighbourhood of the subject site because of-

- (a) the existence on the subject site of buildings or structures which are in a ruinous, derelict or dangerous condition, or
- (b) the neglected, unsightly or objectionable condition of the land or any structures on that land, or
- (c) the presence, deposit or collection on the land in question of any litter, rubbish, debris, waste, or more than one derelict vehicle visible beyond the site, except where the presence, deposit or collection of such litter, rubbish, debris, waste or derelict vehicles results from the exercise of a right conferred by the District Plan or a resource consent.

"Derelict vehicle" means any car, truck, bus, tractor or other vehicle which is not currently registered or warranted as required by law and which is unable to be driven under its own power."

6.1.3 Proposed Change(s) - Parking and Manoeuvring, Vehicle Access and Crossing Standards

.1 THAT Appendix 6 be replaced with the following:

Appendix 6: Parking and Manoeuvring Standards

6.1 MANOEUVRING AND PARKING SPACE DIMENSIONS (METERS)

6.2 LOADING SPACE DIMENSIONS

ORIGINAL SIZE A4

COPY RIGHT© These drawings shall only be used for the purpose for which they were supplied. Any re-use is prohibited and no part of this document may be reproduced or distributed without the written permission of the TARARUA DISTRICT COUNCIL.

Parking Angle	Width of Parking Space	Kerb Overhang	Depth of Parking Space	Manoeuvring Space	Total Depth	
					One Row	Two Rows
90°	2.60	1.0	5.2	7.3	12.5	17.7
	2.75	1.0	5.2	7.0	12.2	17.4
60°	2.60	1.0	5.5	3.8	9.3	14.8
	2.75	1.0	5.5	3.5	9.0	14.5
45°	2.60	0.8	5.2	2.7	7.9	13.1
	2.75	0.8	5.2	2.6	7.8	13.0
Parallel Parking	6.10	0.4	2.5	3.7	6.2	8.7
	6.20	0.4	2.5	3.6	6.1	8.6
	6.40	0.4	2.5	3.3	5.8	8.3
	6.60	0.4	2.5	3.0	5.5	8.0

NOTES:

1. Parking Angle, width of parking space, kerb overhang, depth of parking space, manoeuvring space, and total depth are as shown on the diagram below.
2. Spaces are adjacent to walls or columns should be 300mm wider.
3. One-way traffic is assumed for angle spaces.
4. Carparks shall have a minimum height of at least 2.3 meters, except where special provision is made to divert over height vehicles, in which case the minimum height may be reduced to 2.1 meters.
5. For all retailing and wholesale trading activities, the minimum parking space width shall be 2.6 meters.

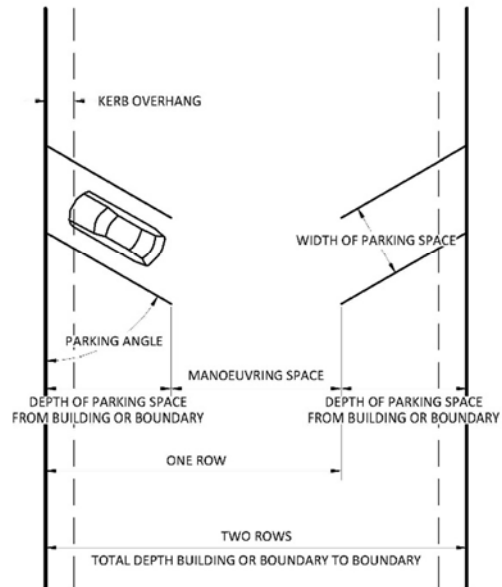

ORIGINAL SIZE A4

	MANOEUVRING AND PARKING SPACE DIMENSIONS (METERS)	
	TARARUA DISTRICT PLAN APPENDIX DRAWINGS	DATE: August 16 SCALE (A4): NTS SHEET NO.: 6.1

COPY RIGHT © These drawings shall only be used for the purpose for which they were supplied. Any re-use is prohibited and no part of this document may be reproduced or distributed without the written permission of the TARARUA DISTRICT COUNCIL.

Any loading space provided in accordance with standard (rule) 5.3.2.3(a) shall be of such dimensions and design as to accommodate the type of vehicle regularly using the site, taking in to account the area and shape of the land available, the purpose of the loading space and the functioning of the building and/or site.

ORIGINAL SIZE A4

 TARARUA [®] DISTRICT COUNCIL	LOADING SPACE DIMENSIONS	
	TARARUA DISTRICT PLAN APPENDIX DRAWINGS	DATE: August 16 SCALE (AS): NTS SHEET NO.: 6.2

COPY RIGHT © These drawings shall only be used for the purpose for which they were supplied. Any re-use is prohibited and no part of this document may be reproduced or distributed without the written permission of the TARARUA DISTRICT COUNCIL.

.2 THAT Appendix 7 be replaced with the following:

Appendix 7: Tracking Curves

7.1 TRACKING CURVE MOTORCAR : 90 PERCENTILE

7.2 TRACKING CURVE TRUCK : 90 PERCENTILE

ORIGINAL SIZE A4

COPY RIGHT© These drawings shall only be used for the purpose for which they were supplied. Any re-use is prohibited and no part of this document may be reproduced or distributed without the written permission of the TARARUA DISTRICT COUNCIL.

AUSTROADS
 DESIGN PASSENGER VEHICLE (5.2 m)
 Radius 6.3 m
 Turning speed 0 - 5 km/h

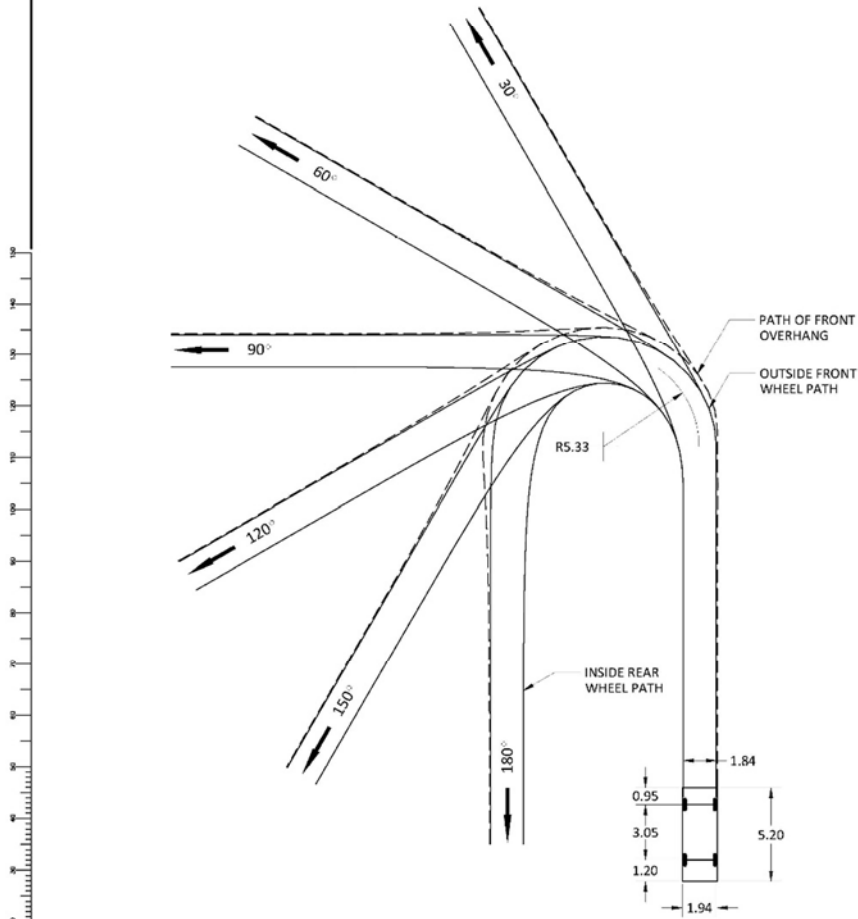

Notes:-

1. Locate face of kerbs at least 0.6 m clear of wheel paths.
2. Allow 0.6 m clearance outside path of overhang and ensure that this area is kept free of road furniture.
3. The outside edge of the swept path remains within the paved area



TRACKING CURVE MOTORCAR : 90 PERCENTILE

TARARUA DISTRICT PLAN
 APPENDIX DRAWINGS

DATE: August 16
 SCALE: NTS

SHEET NO.:
7.1

DO NOT SCALE - IF IN DOUBT, ASK

AUSTROADS
 DESIGN SERVICE VEHICLE (8.8 m)
 Radius 9 m
 For use at mandatory stop only
 Turning speed 0 - 5 km/h

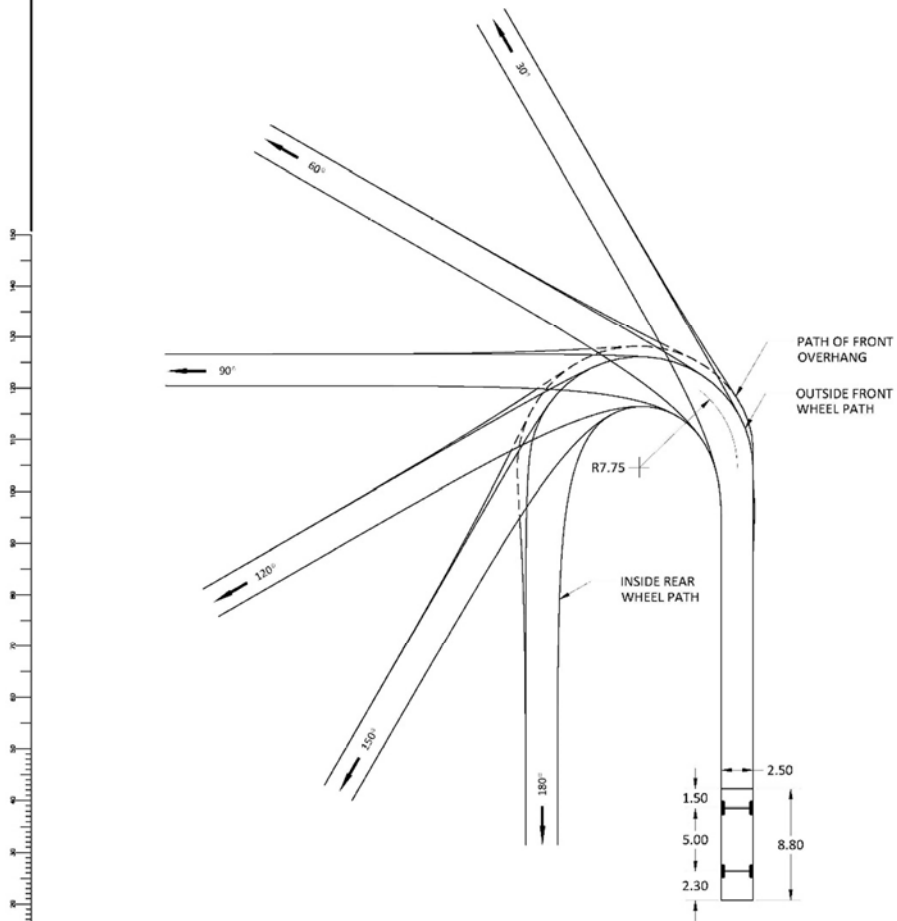

Notes:-

1. Locate face of kerbs at least 0.6 m clear of wheel paths.
2. Allow 0.6 m clearance outside path of overhang and ensure that this area is kept free of road furniture.
3. The outside edge of the swept path remains within the paved area

	TRACKING CURVE TRUCK : 90 PERCENTILE	
	TARARUA DISTRICT PLAN APPENDIX DRAWINGS	DATE: August 16 SCALE (AS): NTS SHEET NO.: 7.2

COPY RIGHT © These drawings shall only be used for the purpose for which they were supplied. Any re-use is prohibited and no part of this document may be reproduced or distributed without the written permission of the TARARUA DISTRICT COUNCIL.

- .3 THAT Appendix 8, Design of Road Access, be replaced with the following:**
- 8.1 That Appendix 8 diagram 8.1 be replaced by the NZTA access standard Diagram C/Perspective C, or amended so that it is wholly consistent with this standard.**
 - 8.2 That Appendix 8 diagram 8.2 be replaced by the NZTA access standard Diagram D/Perspective D, or amended so that it is wholly consistent with this standard.**
 - 8.3 That Appendix 8 diagram 8.3 be replaced by the NZTA access standard Diagram E/Perspective E, or amended so that it is wholly consistent with this standard.**

DO NOT SCALE - IF IN DOUBT, ASK

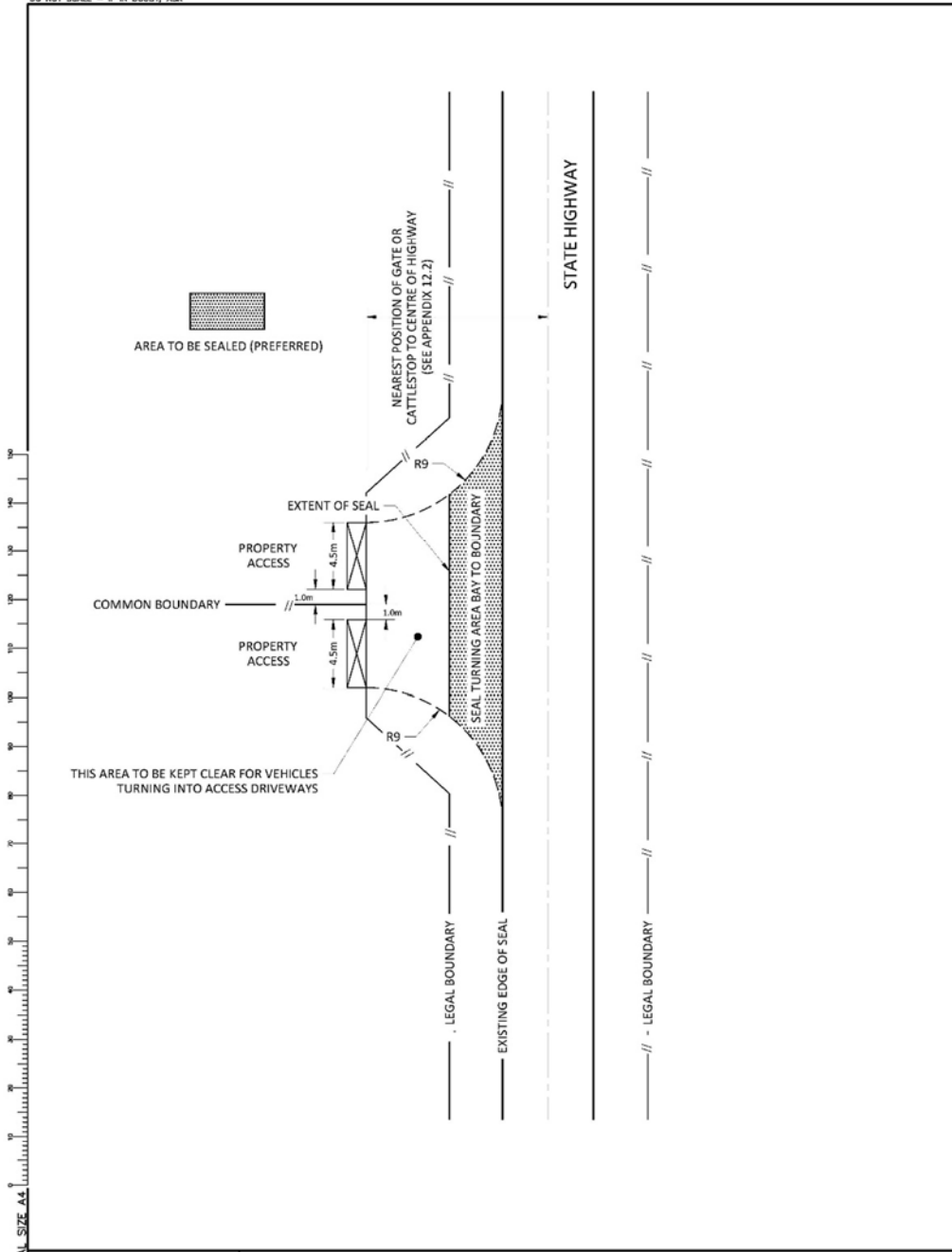

	DOUBLE GATE ACCESS IN RURAL AND SETTLEMENT MANAGEMENT AREAS	
	TARARUA DISTRICT PLAN APPENDIX DRAWINGS	
DATE: August 16 SCALE (A4): NTS	SHEET NO.: 8.4	

COPY RIGHT © These drawings shall only be used for the purpose for which they were supplied. Any re-use is prohibited and no part of this document may be reproduced or distributed without the written permission of the TARARUA DISTRICT COUNCIL.

That the diagram 8.4 key be amended to the following:
Area to be Sealed (Preferred)

.4 THAT Appendix 9 be replaced with the following:

Appendix 9: Design of Access to Primary Arterial Roads

9.1 DESIGN OF ACCESS TO PRIMARY ARTERIAL ROADS IN RESIDENTIAL, COMMERCIAL AND INDUSTRIAL MANAGEMENT AREAS

ORIGINAL SIZE A4

COPY RIGHTS These drawings shall only be used for the purpose for which they were supplied. Any re-use is prohibited and no part of this document may be reproduced or distributed without the written permission of the TARARUA DISTRICT COUNCIL.

DO NOT SCALE - IF IN DOUBT, ASK

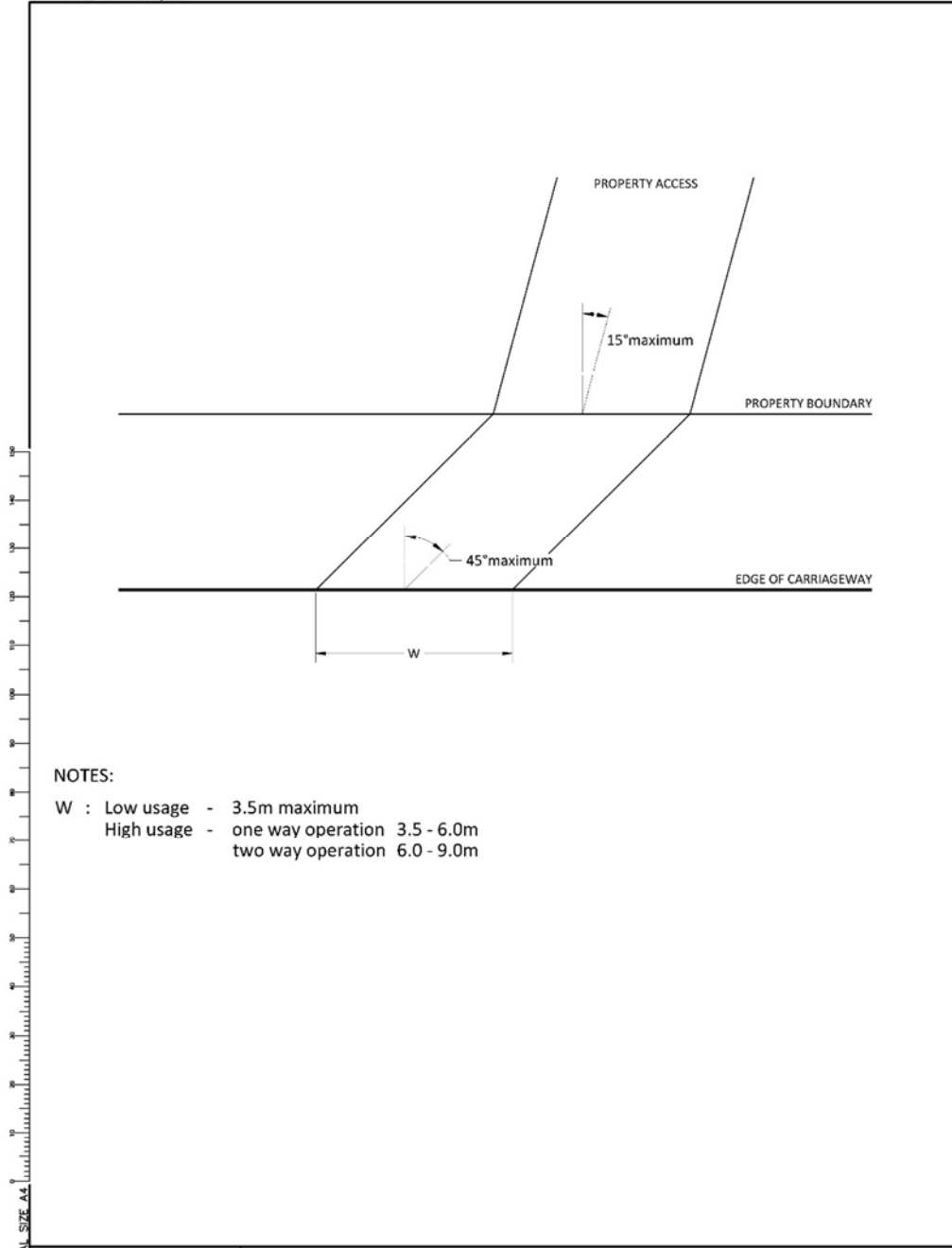

NOTES:

- W : Low usage - 3.5m maximum
- High usage - one way operation 3.5 - 6.0m
- two way operation 6.0 - 9.0m

ORIGINAL SIZE A4

	DESIGN OF ACCESS TO PRIMARY ARTERIAL ROADS IN RESIDENTIAL, COMMERCIAL AND INDUSTRIAL MANAGEMENT AREAS	
	TARARUA DISTRICT PLAN APPENDIX DRAWINGS	DATE: August 16 SCALE (AS): NTS
		SHEET NO.: 9.1

COPY RIGHT © These drawings shall only be used for the purpose for which they were supplied. Any re-use is prohibited and no part of this document may be reproduced or distributed without the written permission of the TARARUA DISTRICT COUNCIL.

.5 THAT Appendix 10 be replaced with the following:

Appendix 10: Performance Standards Relating to Access Spacing and Sight Distances

10.1 PERFORMANCE STANDARDS FOR THE PHYSICAL DISTANCE (SPACING)
BETWEEN ACCESSES AND INTERSECTIONS, AND SIGHT DISTANCE
FROM ACCESSES (PRIMARY ARTERIAL ROADS)

10.2 DIAGRAM A: USING THE ACCESS TABLE - PICTORIAL DESCRIPTION

ORIGINAL SIZE A4

COPY RIGHTS: These drawings shall only be used for the purpose for which they were supplied. Any re-use is prohibited and no part of this document may be reproduced or distributed without the written permission of the TARARUA DISTRICT COUNCIL.

10.1 That Appendix 10.1 be replaced by the NZTA standards:

- **Diagram A/Perspective A – Accessway Sight Lines; and**
- **Diagram B/Perspective B – Accessway Separation from Intersections and Other Accessways or amended so that the appendix is wholly consistent with these standards.**

DO NOT SCALE - IF IN DOUBT, ASK

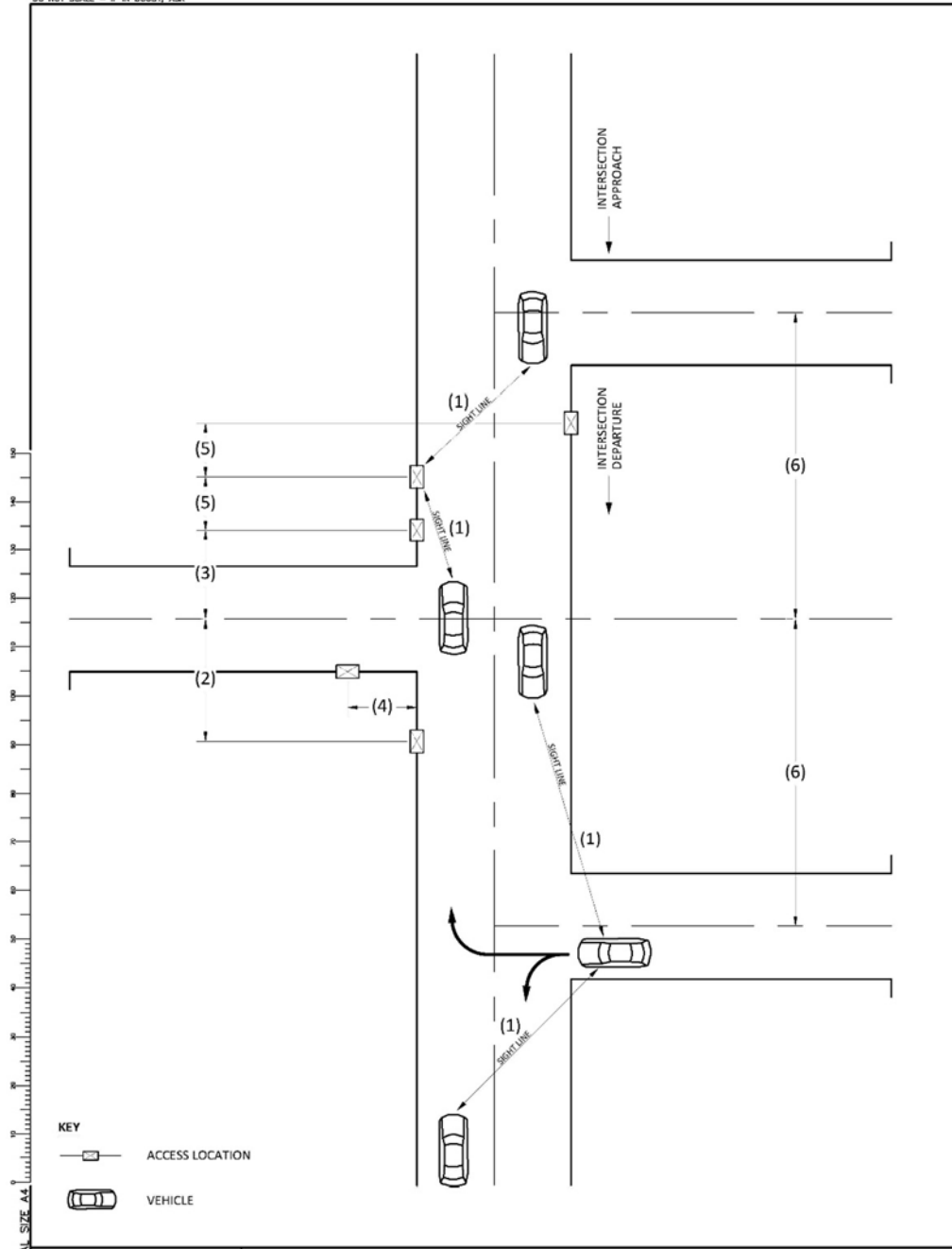

DIAGRAM A: USING THE ACCESS TABLE - PICTORIAL DESCRIPTION

TARARUA DISTRICT PLAN
APPENDIX DRAWINGS

DATE: August 16
SCALE (AS): NTS

SHEET NO.: 10.2

COPY RIGHT © These drawings shall only be used for the purpose for which they were supplied. Any re-use is prohibited and no part of this document may be reproduced or distributed without the written permission of the TARARUA DISTRICT COUNCIL.

.6 THAT Appendix 11 be replaced with the following:

Appendix 11: Construction Standards for Access to Roads other than Primary Arterial Roads in the Residential, Commercial and Industrial Management Areas

- 11.1A STANDARD RESIDENTIAL VEHICULAR CROSSING
TYPE 1: FOR STANDARD ROAD CHAMBER AND LOW PROFILE KERBS
- 11.1B STANDARD RESIDENTIAL VEHICULAR CROSSING
TYPE 2: FOR EXCESSIVE ROAD CHAMBER AND HIGH PROFILE KERBS
- 11.2 STANDARD BRIDGE RESIDENTIAL VEHICULAR CROSSING
- 11.3 STANDARD BERM VEHICULAR CROSSING
- 11.4A COMMERCIAL AND INDUSTRIAL VEHICULAR CROSSING
TYPE 1: FOR STANDARD ROAD CHAMBER AND LOW PROFILE KERBS
- 11.4B COMMERCIAL AND INDUSTRIAL VEHICULAR CROSSING
TYPE 2: FOR EXCESSIVE ROAD CHAMBER AND HIGH PROFILE KERBS
- 11.5 VEHICULAR CROSSING KERB AND CHANNEL DETAILS
- 11.6 EXAMPLES OF TYPE 1 AND TYPE 2 VEHICULAR CROSSINGS

ORIGINAL SIZE A4

COPY RIGHTS: These drawings shall only be used for the purpose for which they were supplied. Any re-use is prohibited and no part of this document may be reproduced or distributed without the written permission of the TARARUA DISTRICT COUNCIL.

DO NOT SCALE - IF IN DOUBT, ASK

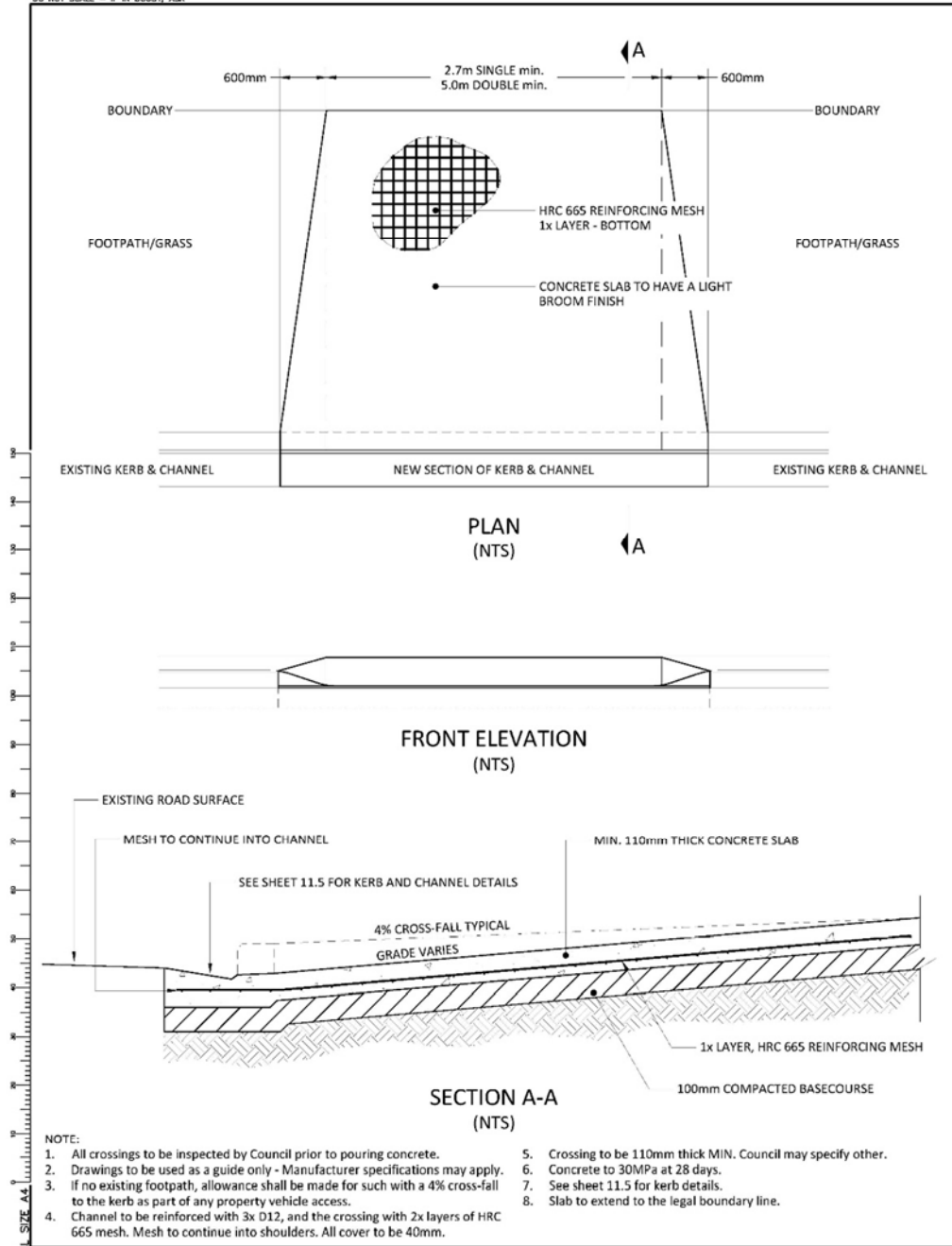

	STANDARD RESIDENTIAL VEHICULAR CROSSING TYPE 1: FOR STANDARD ROAD CHAMBER AND LOW PROFILE KERBS.		<small>SHEET NO.</small> 11.1A
	TARARUA DISTRICT PLAN APPENDIX DRAWINGS		<small>DATE:</small> August 16 <small>SCALE (A4):</small> NTS

COPY RIGHT © These drawings shall only be used for the purpose for which they were supplied. Any re-use is prohibited and no part of this document may be reproduced or distributed without the written permission of the TARARUA DISTRICT COUNCIL.

DO NOT SCALE - IF IN DOUBT, ASK

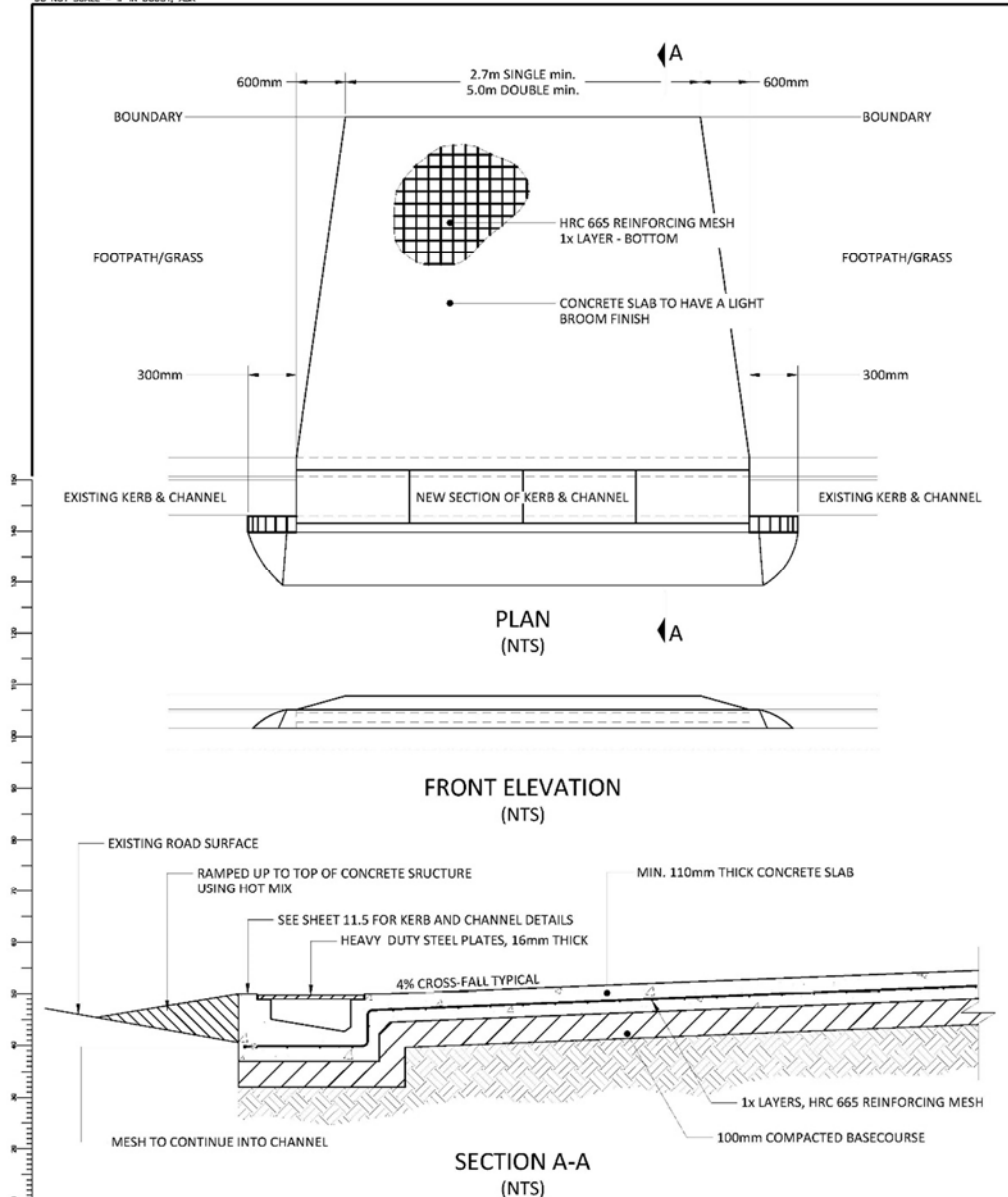

- NOTE:
1. All crossings to be inspected by Council prior to pouring concrete.
 2. Drawings to be used as a guide only - Manufacturer specifications may apply.
 3. If no existing footpath, allowance shall be made for such with a 4% cross-fall to the kerb as part of any property vehicle access.
 4. Channel to be reinforced with 3x D12, and the crossing with 2x layers of HRC 665 mesh. Mesh to continue into shoulders. All cover to be 40mm.
 5. Crossing to be 110mm thick MIN. Council may specify other.
 6. Concrete to 30MPa at 28 days.
 7. Heavy Duty Steel plates to be 16mm thick and to be mortared into place.
 8. See sheet 11.5 for kerb details.
 9. Slab to extend to the legal boundary line.

	STANDARD RESIDENTIAL VEHICULAR CROSSING TYPE 2: FOR EXCESSIVE ROAD CHAMBER AND HIGH PROFILE KERBS.		<small>SHEET NO.</small> 11.1B
	TARARUA DISTRICT PLAN APPENDIX DRAWINGS		<small>DATE:</small> August 16 <small>SCALE (AS):</small> NTS

COPY RIGHT © These drawings shall only be used for the purpose for which they were supplied. Any re-use is prohibited and no part of this document may be reproduced or distributed without the written permission of the TARARUA DISTRICT COUNCIL.

DO NOT SCALE - IF IN DOUBT, ASK

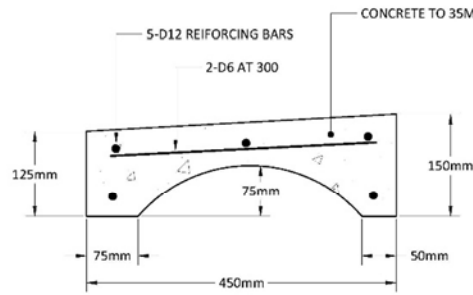

STANDARD PRECAST BRIDGE CHANNEL (450x500)
(NTS)

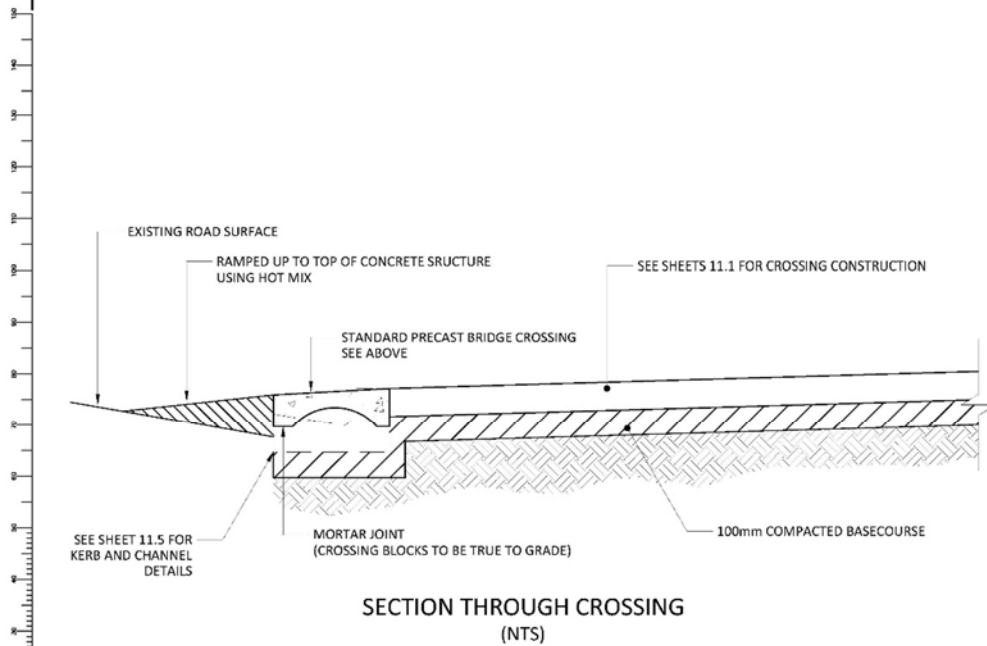

SECTION THROUGH CROSSING
(NTS)

NOTE:

1. See sheets 11.1 for crossing slab construction details.
2. All crossings require council inspection prior to pouring.
3. See sheet 11.5 for kerb details.

ORIGINAL SIZE A4

 <p>TARARUA DISTRICT COUNCIL</p>	STANDARD BRIDGE RESIDENTIAL VEHICULAR CROSSING	
	TARARUA DISTRICT PLAN APPENDIX DRAWINGS	
	DATE: August 16 SCALE (A4): NTS	SHEET NO: 11.2

COPY RIGHT © These drawings shall only be used for the purpose for which they were supplied. Any re-use is prohibited and no part of this document may be reproduced or distributed without the written permission of the TARARUA DISTRICT COUNCIL.

DO NOT SCALE - IF IN DOUBT, ASK

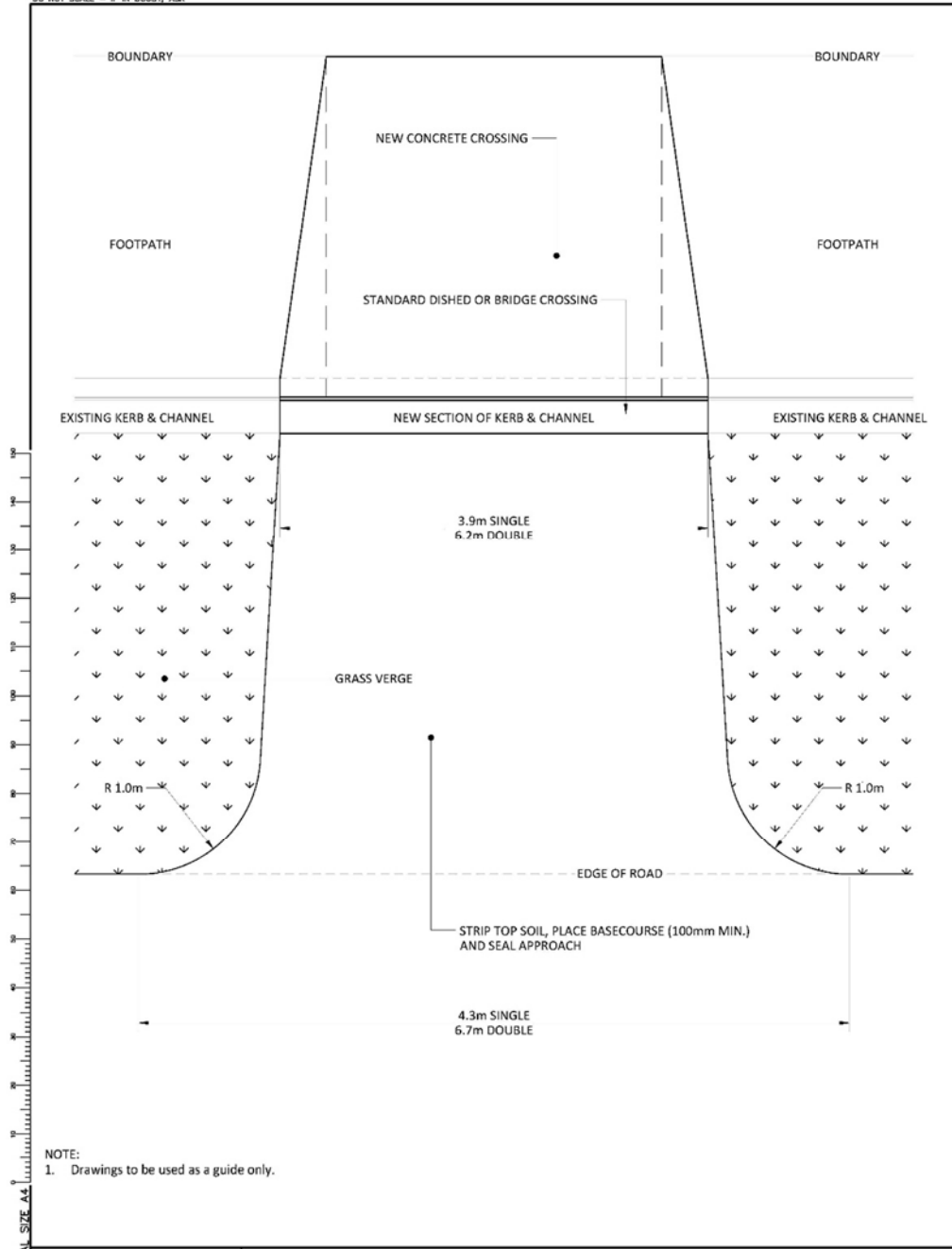

STANDARD BERM VEHICULAR CROSSING

TARARUA DISTRICT PLAN
APPENDIX DRAWINGS

DATE: August 16
SCALE (A4): NTS

SHEET NO.: **11.3**

COPY RIGHT © These drawings shall only be used for the purpose for which they were supplied. Any re-use is prohibited and no part of this document may be reproduced or distributed without the written permission of the TARARUA DISTRICT COUNCIL.

DO NOT SCALE - IF IN DOUBT, ASK

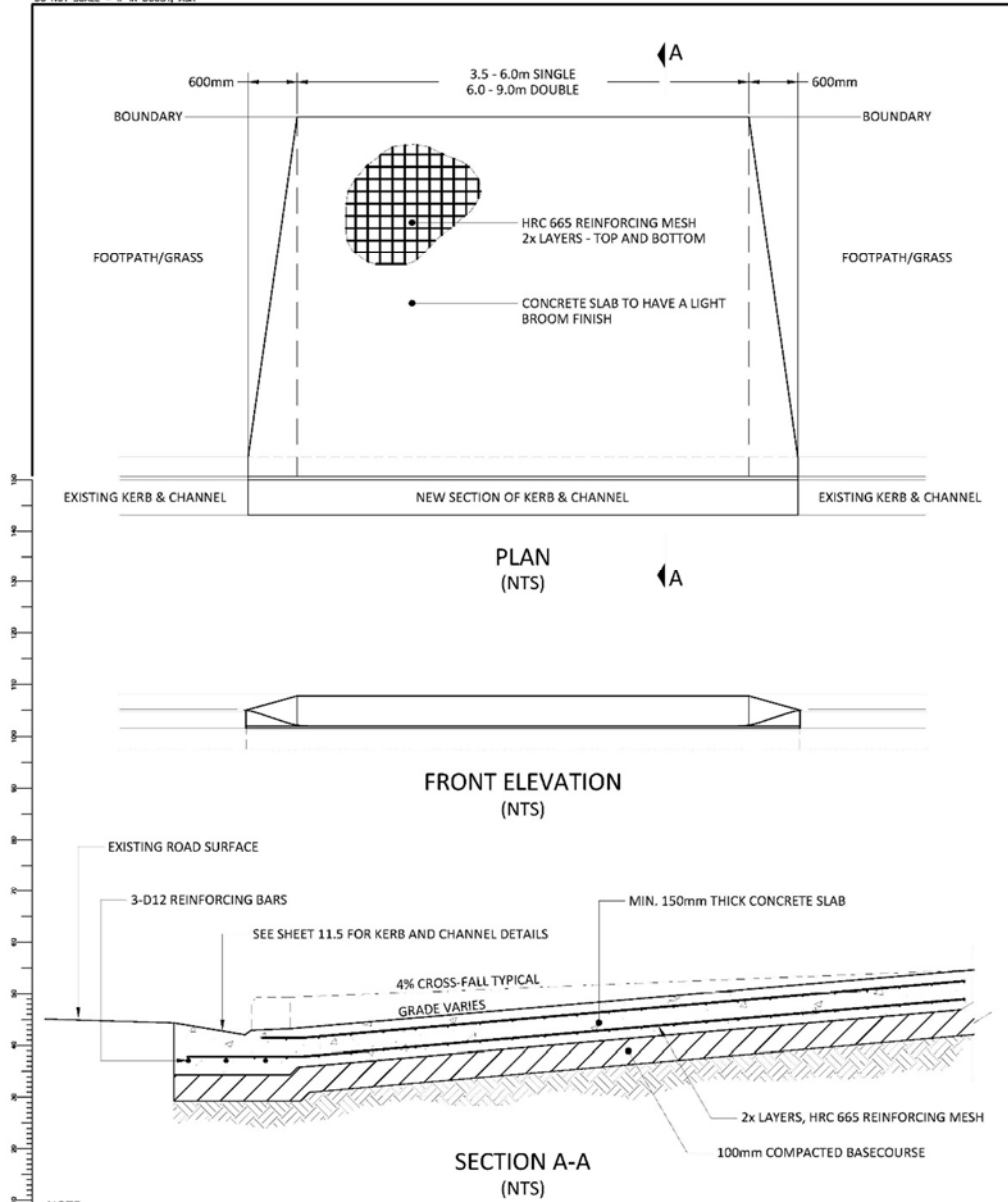

- NOTE:
1. All crossings to be inspected by Council prior to pouring concrete.
 2. Drawings to be used as a guide only - Manufacturer specifications may apply.
 3. If no existing footpath, allowance shall be made for such with a 4% cross-fall to the kerb as part of any property vehicle access.
 4. Channel to be reinforced with 3x D12, and the crossing with 2x layers of HRC 665 mesh. Mesh to continue into shoulders. All cover to be 40mm.
 5. Crossing to be 150mm thick MIN. Council may specify other.
 6. Concrete to 30MPa at 28 days.
 7. See sheet 11.5 for kerb details.
 8. Slab to extend to the legal boundary line.

	COMMERCIAL AND INDUSTRIAL VEHICULAR CROSSING TYPE 1: FOR STANDARD ROAD CHAMBER AND LOW PROFILE KERBS.	
	TARARUA DISTRICT PLAN APPENDIX DRAWINGS	DATE: August 16 SCALE (AS): NTS
		SHEET NO: 11.4A

COPY RIGHT © These drawings shall only be used for the purpose for which they were supplied. Any re-use is prohibited and no part of this document may be reproduced or distributed without the written permission of the TARARUA DISTRICT COUNCIL.

DO NOT SCALE - IF IN DOUBT, ASK

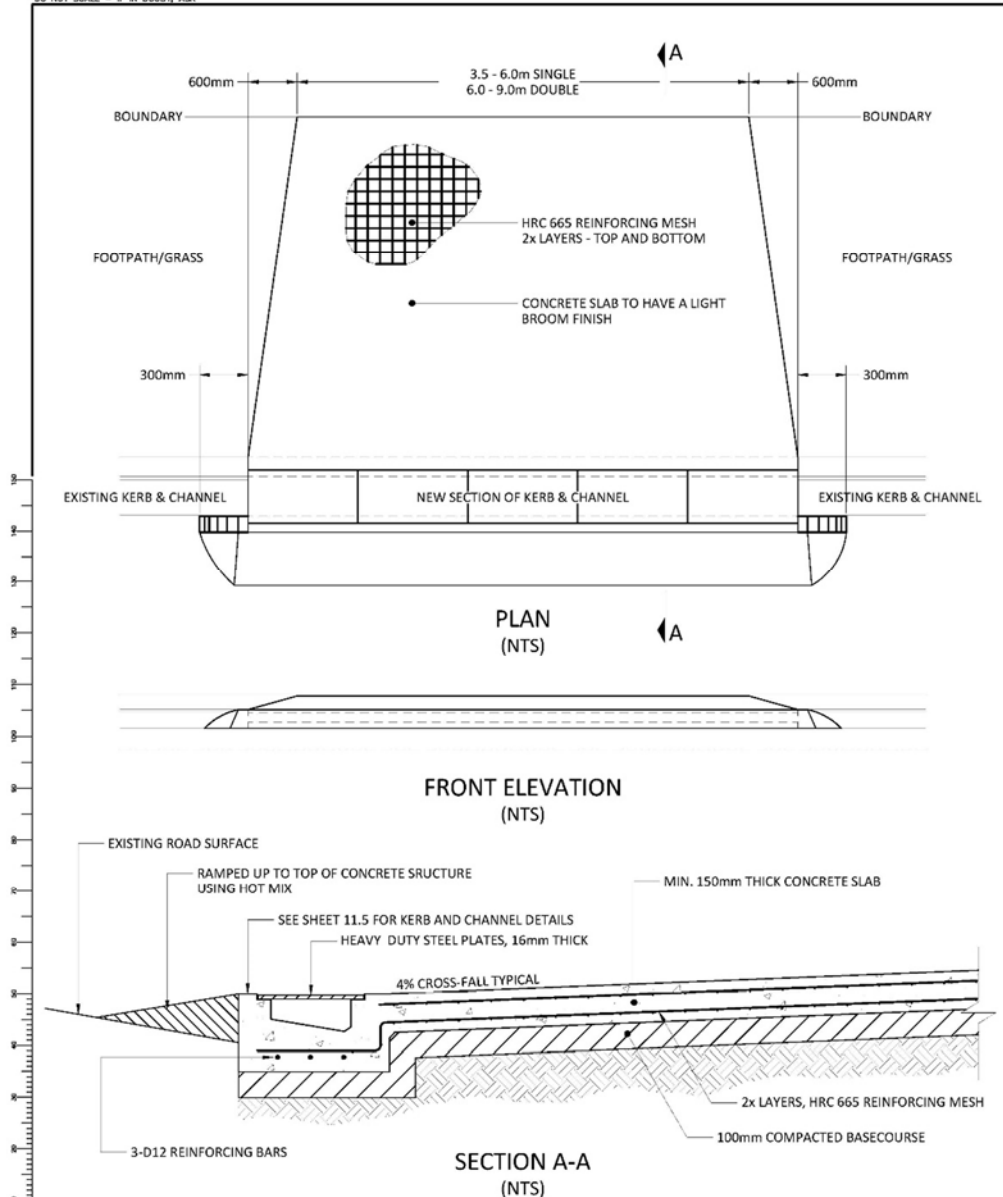

NOTE:

1. All crossings to be inspected by Council prior to pouring concrete.
2. Drawings to be used as a guide only - Manufacturer specifications may apply.
3. If no existing footpath, allowance shall be made for such with a 4% cross-fall to the kerb as part of any property vehicle access.
4. Channel to be reinforced with 3x D12, and the crossing with 2x layers of HRC 665 mesh. Mesh to continue into shoulders. All cover to be 40mm.
5. Crossing to be 150mm thick MIN. Council may specify other.
6. Concrete to 30MPa at 28 days.
7. Heavy Duty Steel plates to be 16mm thick and to be mortared into place.
8. See sheet 11.5 for kerb details.
9. Slab to extend to the legal boundary line.

	COMMERCIAL AND INDUSTRIAL VEHICULAR CROSSING		SHEET NO.
	TYPE 2: FOR EXCESSIVE ROAD CHAMBER AND HIGH PROFILE KERBS.		11.4B
TARARUA DISTRICT PLAN		DATE: August 16	
APPENDIX DRAWINGS		SCALE (A4): NTS	

COPY RIGHT © These drawings shall only be used for the purpose for which they were supplied. Any re-use is prohibited and no part of this document may be reproduced or distributed without the written permission of the TARARUA DISTRICT COUNCIL.

DO NOT SCALE - IF IN DOUBT, ASK

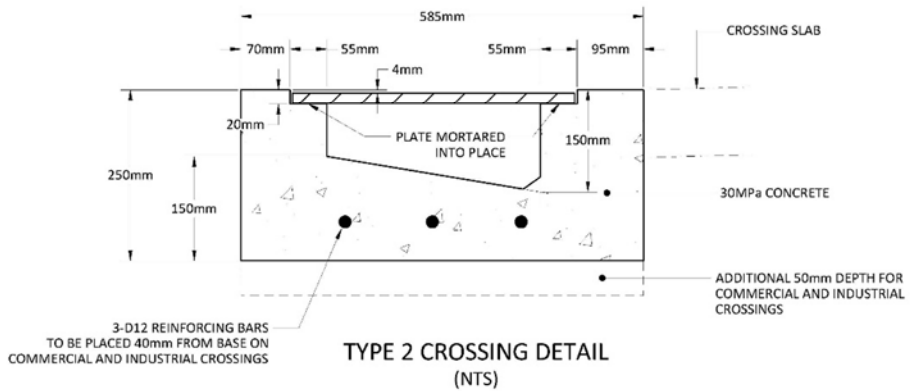
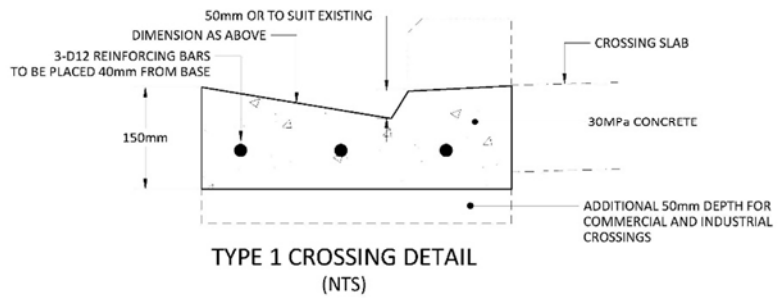
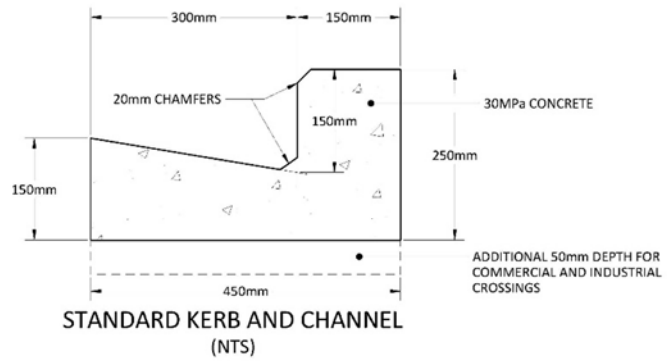

NOTE:

1. All crossings to have engineers approval before pouring concrete.
2. Drawings to be used as a guide only - Manufacturer specifications may apply.
3. Commercial and industrial crossings to have additional 50mm depth and the channel to be reinforced with 3x D12. All cover to be 40mm.
4. Concrete to 30MPa at 28 days. All concrete to comply with NZS3109.
5. Heavy Duty Steel plates to be 16mm thick and to be mortared into place.
6. Profiles may be modified slightly to suit kerbing machine.

ORIGINAL SIZE A4



VEHICULAR CROSSING KERB AND CHANNEL DETAILS

**TARARUA DISTRICT PLAN
APPENDIX DRAWINGS**

DATE: August 16
SCALE (AS): NTS

SHEET NO.: **11.5**

COPY RIGHT © These drawings shall only be used for the purpose for which they were supplied. Any re-use is prohibited and no part of this document may be reproduced or distributed without the written permission of the TARARUA DISTRICT COUNCIL.



TYPE 1 CROSSING



TYPE 2 CROSSING

ORIGINAL SIZE A4



EXAMPLES OF TYPE 1 AND TYPE 2 VEHICULAR CROSSINGS

TARARUA DISTRICT PLAN
APPENDIX DRAWINGS

DATE: August 16
SCALE: NTS

SHEET NO: **11.6**

COPY RIGHT: These drawings shall only be used for the purpose for which they were supplied. Any re-use is prohibited and no part of this document may be reproduced or distributed without the written permission of the TARARUA DISTRICT COUNCIL.

.7 THAT Appendix 12 be replaced with the following:

Appendix 12: Construction standards for Access to Roads other than Primary Arterial Roads in the Rural and Settlement Management Areas

- 12.1 LIGHT VEHICLE ACCESS AND HEAVY VEHICLE ACCESS
- 12.2 FARM ENTRANCES
- 12.3 TYPICAL CROSS SECTION THROUGH ENTRANCEWAY

ORIGINAL SIZE A4

COPY RIGHTS: These drawings shall only be used for the purpose for which they were supplied. Any re-use is prohibited and no part of this document may be reproduced or distributed without the written permission of the TARARUA DISTRICT COUNCIL.

DO NOT SCALE - IF IN DOUBT, ASK

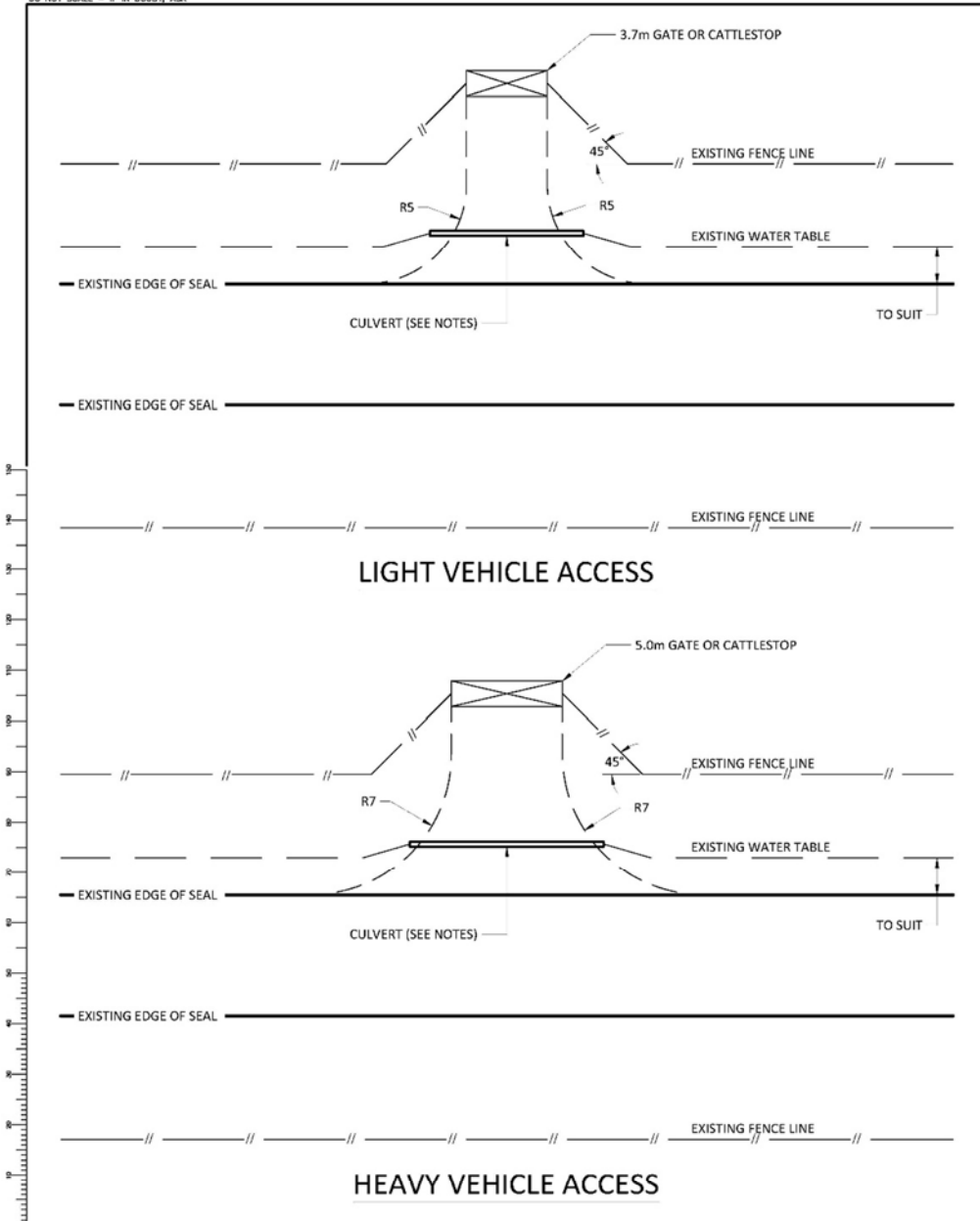

NOTE:
Where the road seal width is narrow, the culvert may be located nearer the gate where the watertable can be graded to it, to allow for future road widening.

	LIGHT VEHICLE ACCESS AND HEAVY VEHICLE ACCESS	
	TARARUA DISTRICT PLAN APPENDIX DRAWINGS	
	DATE: August 16	SHEET NO.:
	SCALE (AS): NTS	12.1

COPYRIGHT © These drawings shall only be used for the purpose for which they were supplied. Any re-use is prohibited and no part of this document may be reproduced or distributed without the written permission of the TARARUA DISTRICT COUNCIL.

DO NOT SCALE - IF IN DOUBT, ASK

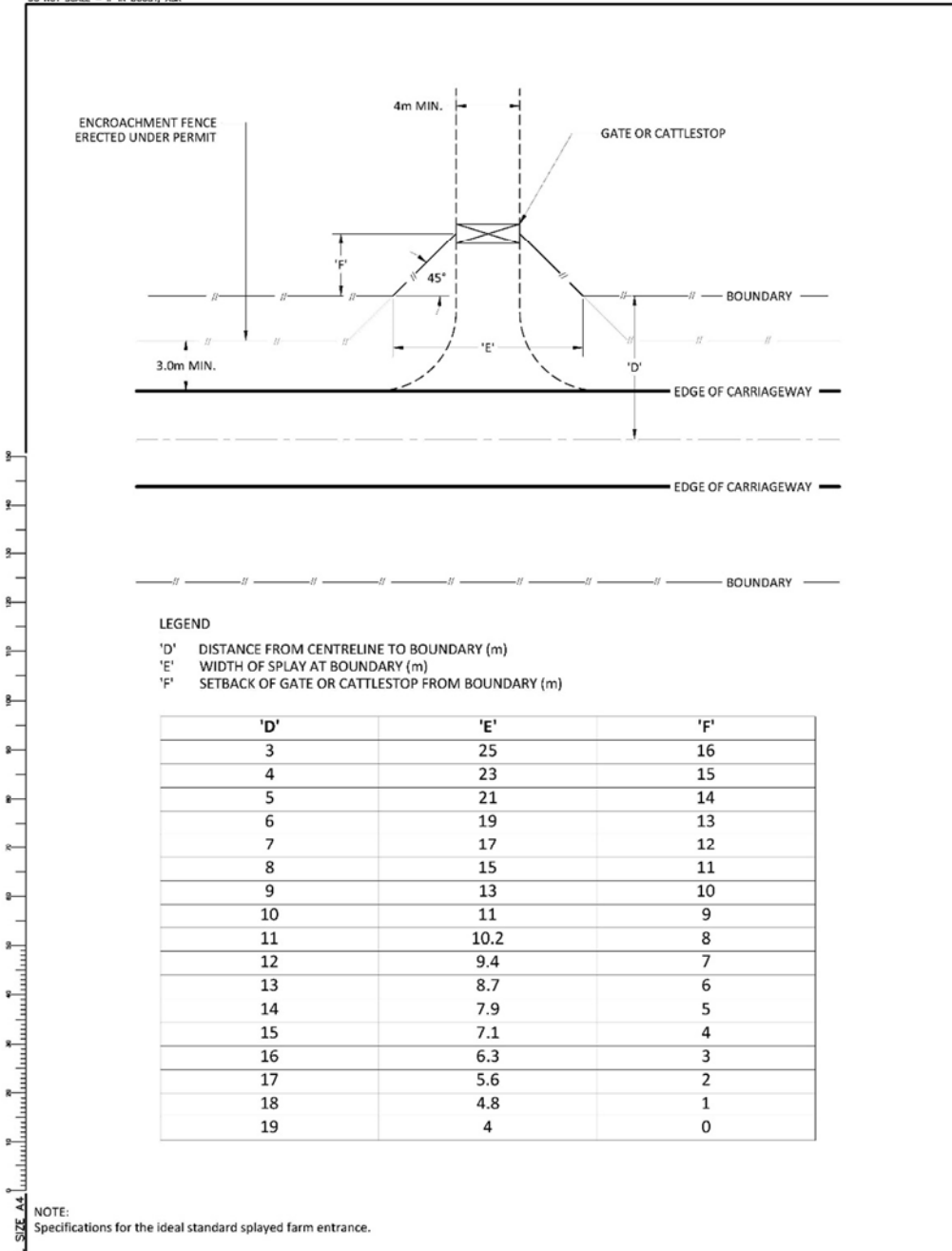

LEGEND

- 'D' DISTANCE FROM CENTRELINE TO BOUNDARY (m)
- 'E' WIDTH OF SPLAY AT BOUNDARY (m)
- 'F' SETBACK OF GATE OR CATTLESTOP FROM BOUNDARY (m)

'D'	'E'	'F'
3	25	16
4	23	15
5	21	14
6	19	13
7	17	12
8	15	11
9	13	10
10	11	9
11	10.2	8
12	9.4	7
13	8.7	6
14	7.9	5
15	7.1	4
16	6.3	3
17	5.6	2
18	4.8	1
19	4	0

NOTE:
Specifications for the ideal standard splayed farm entrance.

	FARM ENTRANCES	
	TARARUA DISTRICT PLAN APPENDIX DRAWINGS	
DATE: August 16	SHEET NO. 12.2	
SCALE (A4): NTS		

COPY RIGHT © These drawings shall only be used for the purpose for which they were supplied. Any re-use is prohibited and no part of this document may be reproduced or distributed without the written permission of the TARARUA DISTRICT COUNCIL.

DO NOT SCALE - IF IN DOUBT, ASK

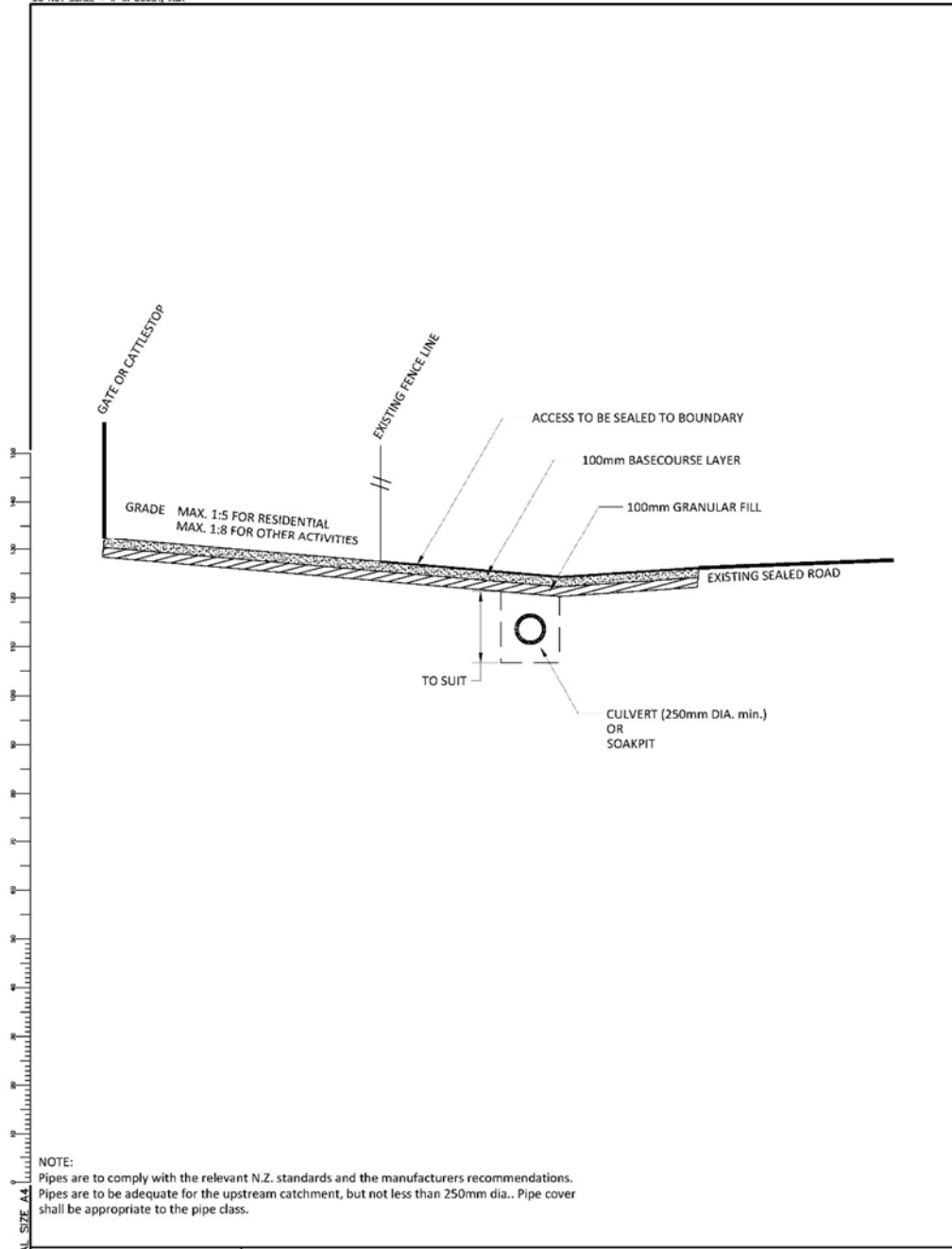

NOTE:
 Pipes are to comply with the relevant N.Z. standards and the manufacturers recommendations.
 Pipes are to be adequate for the upstream catchment, but not less than 250mm dia.. Pipe cover shall be appropriate to the pipe class.

	TYPICAL CROSS SECTION THROUGH ENTRANCEWAY	
	TARARUA DISTRICT PLAN APPENDIX DRAWINGS	DATE: August 16 SCALE: NTS SHEET NO: 12.3

COPY RIGHT © These drawings shall only be used for the purpose for which they were supplied. Any re-use is prohibited and no part of this document may be reproduced or distributed without the written permission of the TARARUA DISTRICT COUNCIL.

6.2.3 Proposed Change(s) - Verandahs

- .1 THAT Schedule 16.1 of Appendix 16 be amended by inserting a column linking the specified street to the relevant District Plan map(s) as follows:

16.1 SCHEDULE OF RETAIL FRONTAGES WHERE VERANDAHS REQUIRED

NOTE: Refer to Section 5.4.9 - applies only to those sections of the specified streets that are in Commercial Management Areas.

Street	Town	<u>District Plan Map Number</u>
High Street	Dannevirke	<u>36</u>
McPhee Street (between High St and service lane)	Dannevirke	<u>36</u>
Allardice Street (between High Street and service lane - both sides of High Street)	Dannevirke	<u>36</u>
Gordon Street (between High Street and service lane - both sides of High Street)	Dannevirke	<u>36</u>
Ward Street (between High St and service lane)	Dannevirke	<u>36</u>
Barraud Street (between High St and service lane)	Dannevirke	<u>36</u>
Station Street (between High St and service lane)	Dannevirke	<u>36</u>
Miller Street (between High St and service lane)	Dannevirke	<u>36</u>
Vogel Street	Woodville	<u>41</u> and <u>42</u>
Main Street	Pahiatua	<u>43</u> and <u>44</u>
Main Street	Eketahuna	<u>46</u> and <u>48</u>

6.3.3 Proposed Change(s) - Resource Consent Application Formats

.1 THAT Rule 7.3.3(i) on page 7-9 be amended as follows:

“(i) Three copies of the subdivision report and three full scale copies of the plan along with a good quality A4 reduction shall be supplied when lodging an application in hard copy form.

A further full scale copy is required in the following situations:

- Amalgamation of Lots;*
- Waiver of Esplanade Reserve;*
- Land abutting a Railway or State Highway;*
- Land abutting land, that is, or will be, the subject of a Heritage Protection Order.*

An application may be lodged with the Council in electronic form, provided it is secure and of a size and in a format able to be accepted by the Council”.

.2 THAT the first sentence in Rule 7.3.2, page 7-5, be amended as follows:

“Information requirements for all consents are required to be submitted with all resource consent applications is outlined in Section 88 and the Fourth Schedule to the RMA (reproduced below).”

and that the reproduction of the RMA’s Fourth Schedule (in italics) on pages 7-6 and 7-7 be deleted from the District Plan.

6.4.3 Proposed Changes – Minor Wording and Updating of References

.1 THAT the second to last paragraph on page 1-5 be amended as follows:

~~“It is considered that this Plan gives effect to the NPSREG. as notified in September 2008. The extent to which the Plan gives effect to the NPSREG will be reconsidered in light of any changes to the provisions of the Plan that become necessary once the MWRC’s Proposed One Plan becomes Operative.”~~

.2 THAT the paragraph concerning the New Zealand Coastal Policy Statement on the bottom of page 1-5 and the top of page 1-6 be amended as follows:

“The first New Zealand Coastal Policy Statement, prepared by the Minister of Conservation, came into force in 1994. An independent review of the NZCPS was conducted between 2002 - 2004 and subsequently, the Minister ~~has notified~~ the Proposed New Zealand Coastal Policy Statement in 2008. It became operative in 2010. The objectives, policies and methods set out in ~~the this Plan~~ relating to the coastal environment aim are designed to give effect to the NZCPS. ~~Any amendments to the District Plan that become necessary when the Proposed NZCPS comes into force will be implemented by way of a plan change or plan variation.”~~

- .3 THAT Sections '1.3.2 Regional Policy Statements and Plans' and '1.3.3 Proposed One Plan' on pages 1-6 and 1-7 be amended as follows:

"1.3.2 REGIONAL POLICY STATEMENTS AND PLANS

Under the RMA, Regional Councils are required to prepare a Regional Policy Statement (RPS) for their region. The District Plan must give effect to any Regional Policy Statement and not be inconsistent with a regional plan for any matter specified in Section 30(1) of the RMA. The purpose of a RPS is to provide an overview of the significant resource management issues of the Region, and to achieve the integrated management of natural and physical resources between district and regional councils. Most of the Tararua District lies within the Manawatu-Wanganui Region and, therefore, the objectives, policies and methods of the Regional Policy Statement section of the One Plan (made operative in 1998-2014) are applicable. In the south east of the District, a small area of land (south of the Owahanga River) lies within the Wellington Region and, in this area, the objectives, rules, and methods of the Regional Policy Statement (made operative in May 1995) for the Wellington Region are applicable. The RPS for each region is a key document in the framework for resource management, and provides policy guidance for the content and scope of the Tararua District Plan.

In addition to Regional Policy Statements, Regional Councils are required to prepare a Regional Coastal Plan and may prepare other Regional Plans relating to any of their functions under the RMA."

Regional Plans provide detailed provisions relating to specific issues. They are necessary where there are resource use conflicts, a high demand for the use of a resource, or for any other significant resource issues.

Regional Plans may be "region wide", e.g. the Manawatu-Wanganui Regional Council's (MWRC's) Regional Air Quality Plan, or they may relate to a specific geographical area or resource, e.g. MWRC's Manawatu Catchment Water Quality Plan.

"1.3.3 Proposed One Plan [Operative as of 19 December, 2014]

The MWRC notified its Proposed One Plan on 31 May 2007. The Proposed One Plan combines the MWRC's operative Regional Policy Statement and Plans into one document. Decisions on submissions to the Proposed One Plan are currently subject to appeals to the Environment Court. As detailed in 1.3 above, the RMA requires that a District Plan must not be inconsistent with a Regional Plan and must give effect to a Regional Policy Statement. Regard has been had to the Proposed One Plan in the District Plan but as the Proposed One Plan is not yet 'past the point of challenge' greater weight has been given to the provisions of the MWRC's Operative Regional Policy Statement and Plans in the preparation of the District Plan. Once the MWRC's One Plan becomes operative, however, changes to the provisions of the District Plan may be necessary in order to ensure that it gives effect to the Regional Policy Statement provisions in the One Plan and is not inconsistent with the Regional Plan provisions of the One Plan, in the interest of integrated management."

- .4 THAT Sections 1.4.5 Population (page 1-14), 1.4.6 Servicing and Infrastructure (page 1-15) and 1.4.7 Economic Base (pages 1-16 and 1-17) be updated as follows:

1.4.5 Population

The Tararua District, at the time of the March 201306-Census, had a "usually resident" population of 17,63116,854 (Statistics NZ 201306). While the District as a whole experienced This was a decline in population of 41.43% during the period between 20061 and 201306, the change in with the population in the main urban centres varyingied from 0-27% to +2.78.6%. Table One shows the populations of the four main towns and the rural areas in the District and the percentage change in population between 2001-2006 and 201306.

Table One: Population within the Urban Centres of Tararua District ("usually resident")					
Urban Centre	1996	2001	2006	2013	Population change between 2001 and 2006 as a %
Dannevirke	5511	5376	5517 23	<u>5,043</u>	2.7 <u>8.6</u> gain/loss
Woodville	1567	1476	1398 1,401	<u>1,401</u>	5.3 <u>loss</u> no change
Pahiatua	2721	2610	2562	<u>2,412</u>	1.8 <u>5.9</u> loss
Eketahuna	642	579	456	<u>441</u>	21.0 <u>3.3</u> loss
<u>Rural Areas</u>	<u>8,598</u>	<u>7,815</u>	<u>7,698</u>	<u>7,557</u>	<u>1.8</u> loss

Within the Tararua District the population is older than the New Zealand average, with those aged over 65 years increasing rapidly. There is an average proportion of young people aged up to 19 years old, but a low proportion of residents aged 20 – 45 years (compared to New Zealand). relatively evenly spread over different age groups. This indicates that an increasing range full range of amenities and facilities need to be provided throughout the District for older people, but facilities for families are also still required.

The 2013 Census population estimates from Statistics New Zealand show a modest increase, driven by positive international migration trends. These recent statistics point to more positive long term projections than those released after the 2013 Census.

The projected resident population of the District for the year 2038~~1~~, using June 2013~~06~~ figures (updated in 2010) as a base (17,450 which includes adjustments for those not covered in the Census), varies from a 5.83.2% increase (if ~~a~~ the high growth period scenario were to occur from 2013~~06~~ to 2033~~1~~) to a loss of 6.38.8% loss for a medium growth period scenario and a 2316.0% loss for a low growth scenario (Statistics NZ, 2015~~0~~). This Plan is consistent with the 2015 LTP and assumes the population of the District as a whole will remain static show a modest growth of 3% over the next decade. However, some townships may continue to experience slow growth in population but necessitate increased development as a consequence of decreasing occupancy rates. The number of occupied households is forecast to increase at a faster rate than overall population due to this trend.

1.4.7 ECONOMIC BASE

Tararua District is a rural district with the economy based largely on primary production. Agriculture is the predominant land use. In the eastern rolling to steep hill country, sheep meat and beef production are the main sources of income, while on the better classes of land in the central valley dairy farming is increasing.

Data from Statistics NZ's Agricultural Census 2012 shows that ~~B~~between 1996 and 201~~0~~2 there was a significant swing to dairy cattle at the expense of sheep, ~~and~~ beef and deer numbers, following a national trend. Numbers of dairy cows increased by ~~38~~26% while sheep numbers dropped by 2516%. ~~This trend changed~~ Livestock numbers change from 2002 to 2007 in response to droughts and export prices. For example, in the period 2012 to 2015, regional survey data shows that stock numbers in the Manawatu-Wanganui Region fell 5.1% for dairy cattle, 2.1% for beef cattle and 1.7% for sheep, ~~as overall stock numbers fell~~. In terms of stock units, sheep farming remains the predominant land use. Since 2007, dairy cattle numbers have grown by 4% (2007 – 2011). The number of farms has dropped by 15% since 1996 as farms are becoming larger in order to gain economies of scale. This has impacted adversely on rural population numbers.

Forestry is a viable land use, but after a busy planting period in the early 1990s very little expansion has taken place. There are many small plantings on farms and few large forestry plantings. In 2012~~07~~ there was ~~162,994-442~~ hectares of exotic forest in the District. ~~The area harvested continues to be larger than the area planted, so the total area in forestry plantations continues to decline.~~ Increasingly, indigenous vegetation such as manuka, is being considered for retention, regeneration and utilisation as a source for honey production on marginal production land throughout the District.

The four main towns of Dannevirke, Woodville, Pahiatua and Eketahuna are service centres for the agricultural sector. In addition they service other categories of economic activity such as ~~industry, manufacturing and tourism.~~

A small number of larger industries include meat processing and steel fabrication, and small scale industries including cottage industries and home occupation are common. Tourism currently makes a small but growing contribution to the District's economy. Tourist attractions include Pukaha Mount Bruce, the Tararua and Ruahine State Forest Parks and an increasing number of owner-operated ventures.

District employment is currently at a moderate level. In recent years there has been growth in manufacturing and servicing and health sector employment. After a long period of stagnation in the agricultural sector, commodity prices recovered from 1999 with the downstream benefits accruing to the wider community. Record prices for milkfat over the last decade have stimulated expansion in the dairy farming sector. More recent declines in the milkfat prices is likely to slow or halt the number of dairy conversions, while beef prices are strong.

The value of Tararua properties, both residential and farming, has risen with the largest increases in value being on dairy farms.

Wind farms have also arisen as an important land use in Tararua that has added value to the District's economic base.

- .5 THAT all outdated references to the MWRC's Regional Policy Statement and Plans and the Proposed One Plan be updated as follows:
- Page 2-13 (first sentence)
"MWRC's ~~Land Management One Plan~~ addresses soil conservation issues in the Region, using a land suite classification approach focussed on 'accelerated erosion' areas."
 - Page 2-17 (first sentence)
"Plan does not contain specific rules regulating vegetation clearance or soil disturbance in vulnerable areas (such as steep hill country), as such rules are contained in the MWRC's ~~Regional Land Management One Plan~~. It is unnecessary and inappropriate to duplicate the rules in this District Plan. Instead, this Plan is intended to complement and reinforce the ~~Regional One Plan.~~"
 - Page 2-18 (first sentence)
"The ~~MWRC's Regional Policy Statement~~ states Council considers that Class I and II land (i.e. elite soils) should be managed to minimise loss of versatility for productive use. ~~and that District Councils should provide the means to achieve this.~~"
 - Page 2-19, 2.3.3.3 Explanation, last sentence of the first paragraph
"Each case will, therefore, be considered on its merits having regard to the relevant standards in Part 5 of this Plan (including effluent disposal and water supply standards). ~~This approach to minimum lot sizes may need to be modified pending the final outcome of the MWRC's One Plan process, as the Proposed One Plan includes rules for minimum land requirements in relation to on-site effluent disposal.~~"

- Page 2-37, 2.5.2.3 Explanation, second sentence
“Policy 2.5.2.2(a) recognises that, in order for the Council, the community and private individuals to make decisions about the use, development and protection of the District's natural and physical resources, it is important that there is a database of information about the natural hazards risk in the District. ~~Both the MWRC's Regional Policy Statement and the Regional Policy Statement section of the MWRC's Proposed One Plan (Part 1, Chapter 9)~~ envisages that the District Council will provide measures to avoid or mitigate natural hazards, including controls on land use and subdivision aimed at avoiding or mitigating the effects of natural hazards. This is the reason for adopting Policy 2.5.2.2(b) above.”
- Page 2-38, 2.5.2.5 Reasons: , third sentence
“Legislative responsibilities for natural hazards under the RMA are shared between Regional and District Councils. The division of responsibility is not entirely clear in the RMA and it is intended that Regional Councils' will provide guidance as to the division of responsibilities for matters relating to natural hazards via the Regional Policy Statement. Policy ~~109~~-1 of the Regional Policy Statement section of the MWRC's ~~Proposed~~ One Plan sets out the responsibilities of the Regional Council and District Council's within the Region in relation to natural hazards.”
- Page 2-41, last paragraph, third sentence
“The Tararua District contains a variety of different landscapes which have been modified to varying degrees by human activities and which together make up the character of the District. In managing the District's natural and physical resources, it is important that consideration be given to the impacts of activities on the District's natural features and landscapes. The Regional Policy Statement (RPS) section of the One Plan for the Manawatu-Wanganui Region identifies (in Policies ~~8-1~~ ~~8-3~~ ~~6-6~~ and ~~6-7~~) several outstanding natural features and landscapes as being "regionally significant" for reasons including visual prominence, scenic characteristics, ecological, cultural or spiritual significance, or other amenity values. The features and landscapes included in the RPS that are within the Tararua District are scheduled in Appendix 3 of this District Plan.”
- Page 2-43, first sentence
“MWRC has a Regional Coastal Plan section in its ~~and the Proposed One Plan in place~~, with which this District Plan shall not be inconsistent.”
- Page 2-53 and 2-54, section 2.6.4.3 Explanation
- Page 5-2, first two paragraphs
“The MWRC's ~~Manawatu Catchment Water Quality Regional Plan and Proposed One Plan~~ also contains rules relating to discharges to land from septic tanks and other effluent disposal standards. The rules aim to ensure that field soakage areas are of sufficient size (having regard to soil types) to ensure that suitable treatment can take place in the field soakage area and in the soil immediately surrounding that area, prior to entering groundwater systems. Developers need to have regard to the requirements of the relevant Regional Council in relation to effluent disposal matters.

It is the MWRC's intention to take primary responsibility for the management of on- site effluent disposal, including minimum allotment sizes, through administration of its 'Manual for On-Site Wastewater Systems Design and Management (Horizons Regional Council, 2010). ~~once the Proposed One Plan becomes operative. In the interim, the relevant District Plan requirements remain applicable.”~~

- .6 THAT all outdated references to the New Zealand Historic Places Trust and the Historic Places Act 1993 be replaced by references to Heritage New Zealand and the Heritage New Zealand Pouhere Toanga Act 2004 respectively.

- .7 THAT Policy Section 2.6.5 THE COASTAL ENVIRONMENT, 2.6.5.3 Explanation, on page 2-57, be amended to reflect the wording of the One Plan, as follows:

"Policies 2.6.5.2(a) and (c) aim to provide guidance as to what subdivision, use and development is considered appropriate in the coastal environment. The term "coastal environment" is used in this Plan in the same context as described in the Regional Policy Statement Chapter 8 of for the Manawatu-Wanganui Region's One Plan where it is defined as: "~~the coastal environment incorporates the environment in which the coast is a significant part, including the coastal marine area, all tidal waters, and foreshore above and below mean high water springs, dunes, beaches, areas of coastal vegetation, areas subject to coastal erosion and flooding, salt marshes, sea cliffs and estuaries.~~" The intention of the policy is not to achieve preservation at all costs. Whether a subdivision, use or development is appropriate, or the location is appropriate, will in part be determined by the extent to which that location still has a natural character, and the extent to which the natural character will be affected by the subdivision, use or development. The use of off-road vehicles such as dune buggies and trail bikes on sensitive coastal sand dune areas (areas where sand is completely or partially exposed) can cause significant damage to the structure and stability of the dune systems and the habitats they support. This is an example of an activity which is generally inappropriate in terms of policy 2.6.5.2(a)."

- .8 THAT Policy 2.6.5.5 Reasons, on pages 2-58 and 2-89, be amended as follows:

"The District Plan seeks to complement the MWRC's One Plan's Coastal Provisions Regional Coastal Plan for the Manawatu-Wanganui Region and the MWRC's Proposed One Plan. ~~This~~ The One Plan contains policies and rules in relation to the coastal marine area which is the "wet" part of the coastal area, below the mean high water springs (high tide) mark. ~~Both these plans~~ It also contains provisions designed to control the discharge of contaminants; taking, use, damming or diversion of coastal waters; activities which disturb the foreshore and sea bed; structures in the coastal marine area; and public access to the coastal marine area."

"Almost all of Taranaki's coastline is within the "General Coastal Area" as defined in the MWRC's Regional Coastal One Plan. ~~as well as the Proposed One Plan~~. Only one part is classified in the One Plan's Regional Coastal Section Plan as a "Protected Protection Activity Management Area", and that is ~~the Cape Turnagain, Fur Seal Hauling Ground~~. This area is deemed to be an area of significant conservation value. Cape Turnagain is identified in this Plan as an important natural feature to be protected."

- .9 THAT Rule 5.1.4.2(b) be amended, as follows:

"(b) In Residential, Settlement, Commercial or Industrial Management Areas, all stormwater shall be disposed of in accordance with Part 4 of (NZS 4404:2010) Land Development and Subdivision Infrastructure."

- .10 THAT Section 5.1.5.1 'Introduction' of the Land Disturbance and Excavation rules in the Plan (page 5-7) be amended by deleting the following words:

"5.1.5.1 Introduction

~~Section 9(4) of the RMA includes the following "uses" in relation to land:~~

~~(b) — any excavation, drilling, tunnelling or other disturbance of the land.~~

~~(d) — and deposit of any substance in, on or under the land."~~

- .11 THAT the introductory section of Rule 5.1.5 Land Disturbance and Excavation (page 5-8) be amended, as follows:

"Mining and quarrying (including ~~prospecting~~, exploration, excavation and processing) are not permitted activities in any Management Area and are, therefore, deemed to be discretionary activities. This enables the Council to assess the proposed work programme and the potential adverse effects of the works, and to set appropriate conditions to protect the amenities of the area."

.12 THAT the Introduction to Section 5.1.7 Natural Hazards (page 5-20) be amended, as follows:

~~“The Regional Policy Statement for the Manawatu-Wanganui Region has defined the respective responsibilities of District Councils and the Regional Council in relation to natural hazards. The Regional Policy Statement states that District Councils are responsible for developing rules for the control of the use of land to avoid, remedy or mitigate the adverse effects of:~~

- ~~• seismic hazards;~~
- ~~• volcanic hazards;~~
- ~~• tsunami hazards;~~
- ~~• subsidence hazards (except as a result of soil disturbance and vegetation clearance which is a Regional Council responsibility); and~~
- ~~• flood hazards (except within floodplains).”~~

~~“Policy 9-1 of the One Plan identifies the respective responsibilities of the Regional Council and territorial authorities. As a territorial authority the Council is required to be responsible for:~~

- ~~• developing objectives, policies and methods (including rules) for the control of the use of land to avoid or mitigate natural hazards in all areas and for all activities except those areas and activities described in 9-1(b)(ii) of the One Plan; and~~
- ~~• identifying floodways (as shown in Schedule J of the One Plan) and other areas known to be inundated by a 0.5% annual exceedance probability (AEP) flood event on planning maps in district plans, and controlling land use activities in these areas in accordance with Policies 9-2 and 9-3 of the One Plan.~~

.13 THAT the following amendments be made to the District Plan maps:

- .1 Amend the ‘Special Rural Area’ notation on the Planning Map Legend to read ‘Urban Buffer Area’ [see Rule 5.2.3.2(d)].
- .2 Change the colour of the lines on the District Plan maps which delineate the Urban Buffer Area to a colour which is less difficult to identify.

.14 THAT Section 5.4.2.1 be amended as follows:

~~“With respect to that part of the District that is within the Manawatu-Wanganui Region, the MWRC’s Regional Air One Plan contains policies, methods and rules for controlling discharges to air, including smoke, dust and odour. It is recognised that the Regional Council is the lead authority in respect of these “air” discharges and, therefore, this Plan seeks only to complement the Regional Council’s requirements, not to duplicate or supplant them.”~~

.15 Page 5-74. Delete the following ‘Note’: from Standard 5.4.2.2(b) in relation to intensive pig farms as the reference no longer applies under the MWRC’s One Plan:

~~“Note: The Manawatu Wanganui Regional Council’s Manawatu Catchment Water Quality Regional Plan also contains requirements relating to the separation distance between any piggery waste disposal area and any dwelling or public gathering place.”~~

6.5.3 Proposed Change(s) - Designations

- .1 THAT Appendix 4: Schedule of Designations, 4.1 Public Works of the Crown (on pages A-37 and A-43) be changed as follows to recognise the uplifting of the Aikitio and Tiraumea Primary School designations:

"21 <u>Deleted</u>	49	Aikitio Primary School	Coast Road Aikitio Lot 1 DP 14161 situated in Blk VII Waimata SD No Gazette Notice reference U25: 988 602	Rural	Minister of Education	School Purposes	<u>Designation uplifted by the Minister of Education by notice to the Tararua District Council dated 1 July, 2015"</u>
-----------------------	----	------------------------------	---	-------	--------------------------	--------------------	--

"48 <u>Deleted</u>	24	Tiraumea Primary	State Highway 52, Tiraumea Sec 25 & 26 Tiraumea settlement contained in Gaz notice 1919 p1490 T25: 678 595	Rural	Minister of Education	School Purposes	<u>Designation uplifted by the Minister of Education by notice to the Tararua District Council dated 13 May 2013"</u>
-----------------------	----	---------------------	---	-------	--------------------------	--------------------	---

- .2 THAT Appendix 4: Schedule of Designations, 4.3 Works of Network Utility Operators Approved As Requiring Authorities (on page A-55) be amended as follows:

"226	18, 45	Pongaroa Substation	Route 52, Pongaroa Lot 1 DP 89223 and Lot 1 <u>DP 484187</u>	Rural	Powerco Limited	Electricity Substation	S168 Notice of Requirement request 5/10/2009 existing work and 17/04/2015 <u>to extend designation"</u>
------	--------	------------------------	--	-------	--------------------	---------------------------	---

- .3 THAT alterations to Schedule 4.3 and to the following District Plan maps be made as follows:

"201	Various	Railway	Various	Various	New Zealand Railways Corporation	Railway Purposes	<u>S168 Notice of Requirement Requests to uplift the designation in part at Station Street Woodville (by notice dated 21/05/2015) and Queen Street Dannevirke (by notice dated 06/11/2015)"</u>
------	---------	---------	---------	---------	--	---------------------	---

- Amend District Plan Map 41 by removing the land identified as Lot 1 on the following Title Plan LT 482807 from Designation D201 and show the land as being zoned 'Rural Management Area'.

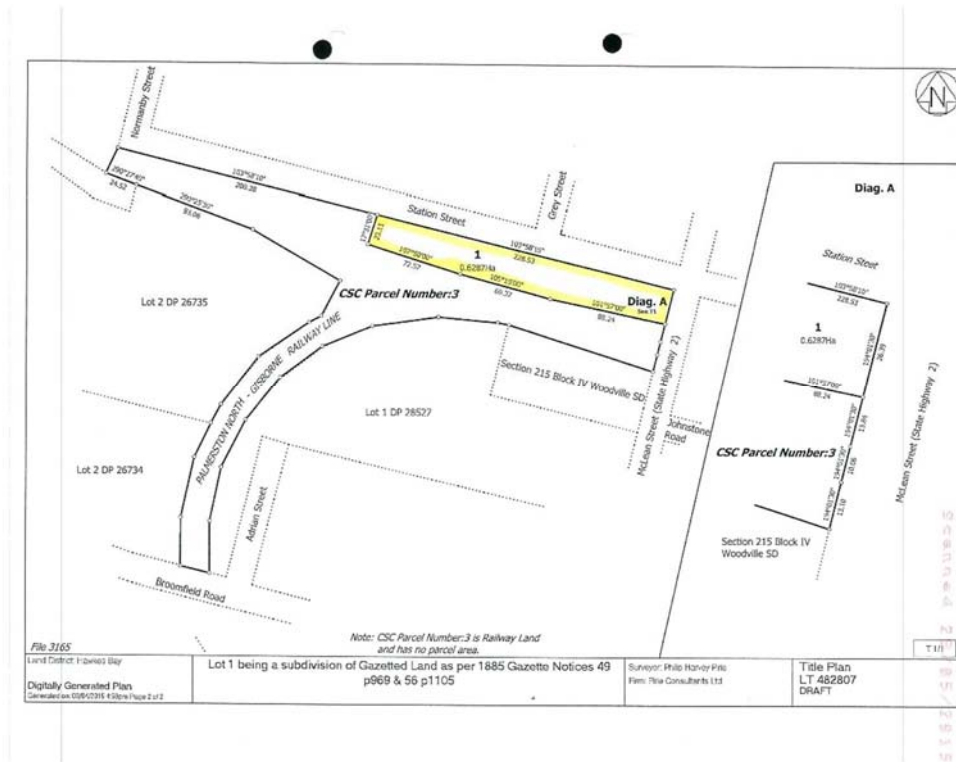

- Amend District Plan Map 36 by removing the land identified as Lots 1 and 2 LT 488502 (see below) from Designation D201 and show the land contained in Lot 1 LT488502 as being zoned Industrial Management Area and the land contained in Lot 2 LT 488502 as legal road.

